

1964

# Digital approach to economic power system loading

Michael Grimes  
Iowa State University

Follow this and additional works at: <https://lib.dr.iastate.edu/rtd>

 Part of the [Electrical and Electronics Commons](#), and the [Oil, Gas, and Energy Commons](#)

## Recommended Citation

Grimes, Michael, "Digital approach to economic power system loading" (1964). *Retrospective Theses and Dissertations*. 2667.  
<https://lib.dr.iastate.edu/rtd/2667>

This Dissertation is brought to you for free and open access by the Iowa State University Capstones, Theses and Dissertations at Iowa State University Digital Repository. It has been accepted for inclusion in Retrospective Theses and Dissertations by an authorized administrator of Iowa State University Digital Repository. For more information, please contact [digirep@iastate.edu](mailto:digirep@iastate.edu).

This dissertation has been 64-10,645  
microfilmed exactly as received

GRIMES, Michael, 1937-  
DIGITAL APPROACH TO ECONOMIC POWER  
SYSTEM LOADING.

Iowa State University of Science and Technology  
Ph.D., 1964  
Engineering, electrical

University Microfilms, Inc., Ann Arbor, Michigan

DIGITAL APPROACH TO ECONOMIC POWER SYSTEM LOADING

by

Michael Grimes

A Dissertation Submitted to the  
Graduate Faculty in Partial Fulfillment of  
The Requirements for the Degree of  
DOCTOR OF PHILOSOPHY

Major Subject: Electrical Engineering

Approved:

Signature was redacted for privacy.

In Charge of Major Work

Signature was redacted for privacy.

Head of Major Department

Signature was redacted for privacy.

Dean of Graduate College

Iowa State University  
Of Science and Technology  
Ames, Iowa

1964

## TABLE OF CONTENTS

	Page
I. INTRODUCTION	1
II. HISTORY OF THE PROBLEM	7
III. REVIEW OF LITERATURE	13
IV. THEORETICAL CONSIDERATIONS	35
A. Basic Theory	35
B. Computer Approach to Solution	47
C. Generalization for More Than Three Machines	53
V. EXPERIMENTAL RESULTS	55
A. Preparation of Data	55
B. Preparation of The Computer Program	60
C. Solution for Three Machines	67
VI. DISCUSSION	77
VII. SUMMARY	84
VIII. REFERENCES	87
IX. ACKNOWLEDGEMENTS	89
X. APPENDIX	90

## I. INTRODUCTION

The basic problem in the electrical power industry today is the obtaining of the maximum power output for the least input fuel cost. As the power systems grow larger the determination of the optimum generation schedule for the system becomes more complex and takes longer to compute. At the same time, as the system grows larger greater accuracy becomes more essential since a percentage saving represents more actual dollar savings on a larger system.

In the early days systems consisted of one generator supplying a number of loads. Then as the system load grew other generators were added in parallel but at the same location. It was then discovered in larger cities that it was more economic to put some of these extra generators closer to the various load centers. As loads grew and became more important, reliability of supply became paramount, but it was not always possible for a town or city to pick up dropped load in the case of an outage. In order to improve the reliability, therefore, cities started banding together so that in the case of an outage in one, the load could be picked up by spare capacity in the next. This was the start of the giant grid of interconnected systems which exists today. At the present time almost all of the major power companies and systems east of the Rockies are interconnected and can transfer power from any system to any other. Also most systems west of the Rockies are interconnected and it is hoped within a few years to have the whole United States as one complete giant interconnected system.

With interconnection it was discovered often that it would be cheaper for a power company under certain conditions to buy power from a neighboring company rather than to generate it itself. Such a case might occur

where two cities are relatively near to each other but in two different time zones. When this happens the peaks in the two cities are staggered by an hour and it would pay one company to borrow power to supply its peak load rather than generate itself. Then when the peak would occur in the second city the first company could help out with extra power. This gave rise not only to the transmission of power in emergency but also to the scheduling of transmission throughout the day. Under these conditions each system could no longer be analyzed economically alone but should be analyzed in conjunction with its neighboring systems.

To further complicate the problems within a system itself, as newer generating units are added these units tend to be larger and more efficient. Most large power systems now have generators in service ranging in age from less than a year to forty years old. Whereas 30 MW was a large generator in the 1930's, utilities such as the New York Edison System are now considering units of 500 MW and larger. One such 500 MW unit is already in service. However, in order to utilize these large units economically they should be in service 24 hours a day. This means that careful scheduling of the equipment is the sine qua non.

As one transmits power from one system to another losses occur. These losses are the penalty paid for the removal of the power from one location to another and are always present. As generators have different efficiencies, it sometimes is more desirable to transmit the power to the load from a high efficiency generator remote from the load, rather than from a relatively inefficient generator close to the load. The determining factor is the cost per unit delivered at the load. In the determination of this the transmission losses play a major part and must be con-

sidered in any solution to the problem.

Another factor which causes the problem to be more complex is that all generating stations are not of the same type. Some may be steam and others hydro. While a steam station can be considered to be available when it is not out for maintenance the same does not apply to a hydro station. Whether or not a hydro station can be utilized depends on many factors such as the amount of water in the reservoir, the weather, flood control, maintenance of sufficient water downstream for ferries and navigation, water supply to cities downstream, etc. All of these factors must be taken into account when assigning hydro generation. In general the maximum output of a hydro station is known as well as the approximate times it will be available. When integrating such a station into the system it will be necessary to work up to that maximum but not over it. The maximum then varies with the above mentioned factors. In a steam station the maximum is always the same.

The purpose of this thesis is to demonstrate an iterative method suitable for digital computer programming which will determine the optimum generation schedule for a large system to provide a given power output at minimum fuel input cost. As with any iterative solution the convergence to the final solution rapidly is of the utmost importance and this thesis demonstrates a method for the rapid convergence of the solution to the desired final solution. It will be demonstrated that this method does give the minimum value of power input for the conditions stated.

It is very difficult if not impossible to get an exact solution to the problem for all possible combinations of the variables. Instead certain of the variables must be presumed fixed and the solution iterated for multiple values of the others until a minimum input is obtained. If desired, then

some of the variables previously fixed may now be varied and further iterations performed until an absolute minimum power input is obtained.

In this thesis what has come to be known as the phase angle method will be used and this involves a solution of a trigonometric nature. The network first has to be described and in order to do this it is necessary to know the transfer impedances among each and every pair of generators. If the system be simple then this is not a difficult problem, but if the system be more complex resort to other means will have to be made. They can be calculated either with a network analyzer or by means of a digital computer. The first method is the older of the two and has the disadvantage of not being very accurate. However it is relatively simple and cheap if an analyzer is convenient. The digital computer can be programmed to give the results to any degree of accuracy. In this thesis the system was presumed given.

Care must be exercised in using an analyzer or computer to find the transfer impedances in that the system loads should be trimmed to the correct impedance values at the desired voltages. Once the loads are trimmed these values will then represent the loads and it will be assumed the impedances will not vary with voltage. If the final solution therefore differs widely in voltage from the values for which the transfer impedances were obtained the accuracy of the solution will be seriously impaired. It is therefore essential to exercise good judgment in trimming the system and perhaps only experience will give this.

There will be few restrictions placed on the system. At first a solution will be obtained for fixed voltage magnitudes and varying voltage phase angles. Having then determined the optimum phase angles the solution



will be considered for load voltage profiles varying slightly from the presumed values. An absolute minimum will then be obtained. For this purpose one voltage at one generator will be considered fixed as obviously if no voltage is stated, then the general principle that the higher the voltage the less the losses and the less the fuel input will apply. However once one voltage is fixed then there will be at least one optimum profile in the system. In a large system there will be many solutions close together and the best one will be a matter of engineering judgment.

If the optimum voltage profile is not available with present equipment then it may have to be built up or reduced by physical means such as capacitors, etc. It will be generally true that the larger the system, while there will be only one solution for the various phase angles holding the magnitude of the voltages constant, there will be a number of solutions giving various voltage profiles. The system offered in this thesis will guarantee a minimum power input for the conditions stated.

It will also be possible as a by-product to calculate the var schedule and the transmission losses though it should be pointed out that the losses in themselves do not mean very much. There is no point trying to minimize the losses unless it also reduces the fuel input cost. In this thesis the emphasis is on minimizing the fuel input and the losses are not considered directly, as with the system chosen they are automatically accounted for in the calculations. The results of the var flow profile may be somewhat surprising if not impracticable but corrective action can be taken to minimize this flow by changing the voltage in the system. It will generally be found that the var flow can be minimized by suitable choice of one of the economic voltage profile solutions.

The last item of importance is how quickly a solution can be obtained. It is obviously futile to attempt to use a method if the time taken for calculation exceeds the time available for computing. This thesis will demonstrate a method of convergence which should help to speed up the work and keep computing time to a minimum. It will generally be found that if the first attempt is close to the actual values, solutions will be obtained more rapidly. In general this will be the rule as with most practical systems the approximate range of the solution will be known from experience.

Because of the following trends in the growth of power systems it has become progressively important to give increasing attention to economic system operation:

1. In many cases economic factors and the availability of primary essentials, such as coal, water, etc. dictate that new generating plants be located at greater distances from the load centers. This applies particularly in the case of nuclear plants.
2. The installation of large blocks of power has resulted in the necessity of transmitting power out of a given area until the load in that area is equal to the new block of installed capacity.
3. Power systems are interconnecting for purposes of economy interchange and reduction of reserve capacity.
4. In a number of areas of the country the cost of fuel is rapidly increasing.

## HISTORY OF THE PROBLEM

About 1942 considerable investigation was started into the determination of accurate transmission loss formulas. In this year E. F. George<sup>10</sup> developed a superposition method which required operating each plant in turn to carry the whole system load. Then when the individual loads were reduced pro rata to stay within the plant rating, the voltage drops were sufficient to bring the substation voltages below normal, thus reducing the loads and distorting the line currents. The pro rata reduction of the loads to fractional values was foreclosed by the necessity of maintaining reasonably accurate and readable values of power flow in the most lightly loaded lines. Power factor and voltage corrections were made on the basis of system average conditions. This method was reasonably accurate for use by longhand computation but was only useful then because during the war, time was hard to get on calculating boards and other alternatives had to be considered.

In 1946 after World War II, the superposition method came in for closer scrutiny and a number of developments were noted including a source-by-source adjustment for voltage and power factor. Efforts were also made to correct for some of the errors in calculating the transmission losses.

By 1948 it was becoming apparent that the superposition method was anything but ideal and furthermore as systems grew more complex this method grew in its complexity. About this time a paper<sup>27</sup> was presented which gave a method for combining incremental fuel cost and incremental transmission loss in an effort to predict optimum scheduling but this, while not contributing anything new in theory, did increase the usefulness of

the loss formulas because it used the partial derivatives of the B constants as one of the important components in the loading equations. At this time an a-c calculating board was being used as the digital and analog computers did not arrive in general use for some years. However, when they did arrive these basic formulas could be used with but little alteration. The problem was that linear simultaneous equations could not be solved in any great number until the advent of the digital computer.

The next improvement, which came in 1949, was the principle of coincident superposition. This method used two sources simultaneously supplying the open-circuited transmission system. This in combination with the normal power flow study, permitted by subtraction, the determination of the flow from each source separately. This actually was applying the principle of superposition in reverse but it did give more nearly normal voltages and also more readable power flow in the lines. This method would actually have been more suited to the computer since it involved many changes of source and then many adjustments at each source. Part of this method developed simple incremental loss formulas without developing a total loss formula.

About 1951 Kirchmayer<sup>19</sup> started some intensive investigations into the whole problem and particularly into the determination of the loss coefficients. He not only developed many methods of his own but also gathered together most previous methods and coordinated them. These he later published in book form. His first attempt was a method presented at the 1951 AIEE Summer convention and which described an improved method of deriving a total transmission loss formula requiring considerably less network analyzer and arithmetic calculations. At the same time the discrepancies in this method were evaluated. Kron<sup>21</sup> at the same meeting presented a method

of applying tensor analysis to power systems.

In 1952 considerable interest was displayed in the coordination of incremental fuel costs with incremental transmission losses. Kirchmayer<sup>20</sup> again did most of the work and presented a paper which gave:

1. A mathematical analysis of various methods of coordinating incremental fuel costs and incremental transmission losses.
2. An evaluation of the errors introduced in the optimum system operation by assumptions involved in determining a loss formula.
3. An evaluation of the savings to be obtained by coordinating incremental fuel costs and incremental transmission losses. Kirchmayer generally coordinated most of the other work in the field.

In 1953 the digital computer started coming into its own and naturally the first applications were to apply it to methods already extant. This shortened the time considerably on these methods but they were developed in the first place for longhand calculations and were not designed to make full use of the versatility of a computer. An iterative method of calculating generation schedule was also introduced<sup>13</sup>. For a given load the computer was programmed to calculate the incremental cost of received power, total transmission losses, total fuel input, penalty factors and received load, along with the allocation and summation of generation. This was probably the first iterative solution on a large scale and was reasonably successful. By 1954 the computer was more readily available and many people tried solving loss formulas in an easier manner. The main starting point was the removal of the matrix algebra which while suitable for longhand was unsuited to a computer. Simple algebraic equations were developed<sup>16</sup>. Block diagrams were also brought in about this time.

Also the voltage phase angle method was developed<sup>2</sup> and this was a completely new procedure and a new tool and was very useful for checking loss calculations. It was particularly noted that incremental loss in a transmission line was very closely proportional to the voltage phase difference across the line. Now flexibility in voltage phase levels and reactive power became possible.

Cahn<sup>4</sup> developed in 1955 an analytical derivation of the phase angle method which gave greater strength to this theory. It was also shown that this method was a major improvement in accuracy. Also a stumbling block up to this was the determination of the open circuit impedances. With the coming on the market of large computers it became possible to have a computer compute these and some development was also done in this direction. In other studies<sup>9</sup> a new constant  $B_0$  was added to the B-constant method because it was found that the B constant method just was not accurate enough when the load did not vary in the same ratio between substations at various times of the day and year. Another study at the time<sup>5</sup> also showed that the partial derivatives of the B constants are anything but completely independent variables and that each pair of power flow studies may be planned to yield data on several incremental coefficients.

In 1956 E. D. Early did some interesting work in adopting a scheme whereby instead of relying on the minimum required number of power flow studies, he used all available power flow studies and to these applied the method of least squares to reconcile the resultant equations. This naturally added to the amount of calculations but Early also found that Houghton's formula permitted direct reduction of the rectangular given matrix to a smaller equation matrix:

$$B = (M_t M)^{-1} M_t K$$

B = loss coefficient

M = given matrix

(1)

$M_t$  = transpose of M

K = known (or right hand column of given values)

At the same time a completely new approach<sup>7</sup> was developed for obtaining the transmission loss and this method used only the basic impedance data of the transmission network plus substation load levels and source loadings. The equations were very elaborate and necessitated use of a digital computer solution with a minimum of system measurements but for minimum loss conditions the procedure was reduced to the simplicity of a d-c network analysis.

The American Gas and Electric Service Corporation installed an incremental transmission loss computer in their Columbus Production and Coordination Office specifically for the use of the system load dispatcher. This computer calculated the incremental transmission losses and penalty factors for various system operating conditions. The coordinated operation of this computer and the incremental cost slide rule furnished a flexible and accurate method for taking into account the various and rapidly changing system conditions in the plant and on the transmission system. Other computer developments included analog dispatching computers which incorporated both plant incremental cost representation and penalty factor computation within the computer.

Around 1957 rapid progress was made by the industry in developing automatic and economic automation schemes whereby system frequency, net interchange and economic allocation for generation for a given area are simul-

taneously and automatically maintained. These devices offered important savings as they:

1. Improved the fuel economy by closer adherence to the optimum schedule than would be possible by manual operation.
2. Saved many man hours by elimination of certain manual procedures.

During 1958 the phase angle method came in for close scrutiny. At Iowa State University, Dr. J. E. Lagerstrom<sup>22</sup> developed this method and showed how it could be developed further for larger systems. This was a new approach to the problem and gave an optimum system schedule for minimum fuel input provided voltage magnitudes stayed fixed in the system and only the phase angles varied. Brownlee<sup>2</sup> also did some work on this method, but Lagerstrom's method was a more general solution than the Brownlee method.

During 1959 further generality in transmission loss equation was obtained by mathematical analysis and iterative solutions were given greater attention as faster computers came into service. The problem here was the time taken for computation and various methods were tried to shorten these. This was basically the pattern of the work done during this year and succeeding years to date.



## III. REVIEW OF LITERATURE

Kirchmayer<sup>17</sup> published in 1958 a book which coordinated most of the previous methods prior to this time. Starting with steam plants the incremental fuel rate is defined as a small change in the input divided by a small change in the output. The units associated with incremental fuel rate are BTU per kw-hr and are the same as the heat-rate units. The incremental fuel rate is converted to incremental fuel cost by multiplying the incremental fuel rate in BTU per kw-hr by the fuel cost in cents per million BTU. The incremental fuel cost is generally expressed in mills per kw-hr or dollars per mw-hr.

The incremental production cost of a given unit is made up of incremental fuel cost plus the incremental cost of such items as labor, supplies, maintenance and water. It is necessary for a rigorous analysis to be able to express the cost of these production items as a function of the instantaneous output. However no methods exist at the present time for expressing the cost of labor, supplies or maintenance accurately as a function of output. Instead arbitrary methods of determining incremental costs of labor, supplies and maintenance are used, the commonest of which is to assume these costs to be a fixed percentage of the incremental fuel costs. In certain areas of the country such as Texas, water costs form an appreciable part of the incremental fuel costs. In many systems, for the purpose of scheduling generation, the incremental production cost is assumed to be equal to the incremental fuel cost.

He then discusses optimum scheduling and starts by neglecting transmission losses. Under these conditions if:

$$F_n = \text{input to unit } n \text{ in dollars per hour}$$

$F_t$  = total input to system in dollars per hour

$$\text{then } F_t = \sum_n F_n \quad (2)$$

It is desired to schedule generation such that  $F_t$  is a minimum with the restriction that

$$\sum_n P_n = P_R$$

received load, where  $P_n$  = output of unit n.

He then shows that the above conditions are satisfied when:

$$\frac{dF_n}{dP_n} = \lambda \quad (3)$$

where

$$\frac{dF_n}{dP_n} = \text{incremental production cost of unit n in dollars per Mw-hr.}$$

$\lambda$  = incremental cost of received power in dollars per Mw-hr.

The value of  $\lambda$  must be chosen so that  $\sum P_n = P_R$ .

In other words, the minimum input in dollars per hour for a given total load is obtained when all generating units are operated at the same incremental production cost. Increasing  $\lambda$  results in an increase in total generation while decreasing  $\lambda$  results in a decrease in total generation. He notes though that the total cost varies slowly with changes from the minimum cost point.

This is but one method of scheduling generation. Other methods which are still used are:

1. Base Loading to Capacity. The turbine generators are successively loaded to capacity in the order of their efficiencies. This is particularly used when most of the generation is in the same area and becomes less accurate as transmission distances increase.

2. Base Loading to Most Efficient Load. The turbine-generator units are successively loaded, in ascending order of their heat rates, to their most efficient loads. When all units are operating at their most efficient loads they are loaded to capacity in the same order.

3. Proportional to Capacity. The loads on the units are scheduled in proportion to their rated capacity.

All of the above do not take into account transmission losses and since in modern systems these are a major factor he then goes on to investigate these and their effect.

In the general case all sources of generation are not located at the same bus but are connected by means of a transmission network to the various loads. Some plants will be more favorably located with respect to the loads than others. Also, if the criterion of equal incremental production costs is applied there will be transmission of power from low cost areas to high cost areas. It will be necessary, of course, for optimum economic operation to recognize that transmission losses occur in this operation and to modify the incremental production costs of all plants to take these losses into account.

A very simple representation of what is meant is given by the example of figure 1. The system is a simple representation of the American Gas and Electric System (1950) and illustrates the relatively high cost of generation on the Indiana Division (Area 2) as compared to the low cost generation in the Ohio region (Area 1). By the incremental cost theory each generator would supply 150 MW for a total load of 300 MW while it turns out in practice that it is more economical for Area 1 to generate 190 MW and Area 2 to generate 130 MW. It will be noted that there is 20 MW of transmission

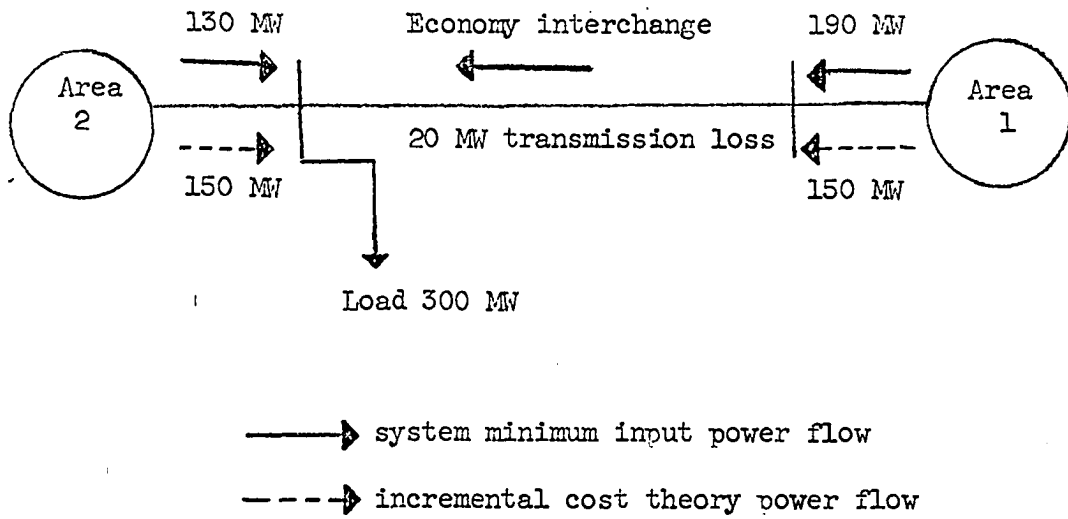

Figure 1. Schematic representation of the system.

loss.

In order to develop a transmission loss formula certain assumptions will have to be made. The transmission losses may be closely approximated by means of a transmission loss formula of the form

$$P_L = \sum_m \sum_n B_{mn} P_m P_n$$

when  $B_{mn}$  = loss formula coefficients (4)

$P_m$  = source powers

The loss-formula coefficients may be considered as an equivalent transmission loss circuit from each generating source to the hypothetical load.

The assumptions involved in deriving a loss formula of this kind are:

1. The equivalent load current at any bus remains a constant complex fraction of the total equivalent load current. Nonconforming loads may be treated as negative sources in the formula or in special cases may be handled by a loss formula including linear terms and a constant term in addition to the quadratic terms ( $\sum_m \sum_n B_{mn} P_m P_n$ ).

2. The generator bus voltages are assumed to remain constant.

3. The generator bus angles are assumed to remain constant.

4. The source reactive power may be approximated by the sum of a component which varies with the system load and a component which varies with the source output. The discrepancies naturally arise due to changes in the above assumptions as the load changes.

He then goes on to discuss a computer program for evaluating the formulas and points out that a considerable reduction in time can be obtained through their use. However in these formulas there are more assumptions than seem warranted for an exact solution of the problem. As a result he

comes up with the not too unexpected conclusion that for a large integrated power system, savings of a considerable magnitude can be realized when the effects of transmission losses are included in the economic scheduling of generation.

He then discusses iterative solutions on a computer and concludes that the use of an iterative approach with an automatic digital computer is particularly valuable in precalculating schedules and in undertaking special studies. Since the computer program is general, a single routine is maintained in the computer-program library, which will permit scheduling of any size system in a practical manner. In addition to printing the allocation of generation, the digital computer also presents in printed form the incremental cost of the received power, total transmission losses, received load, unit fuel input and total fuel input for the system. The last four quantities are the most difficult to calculate with generally available analog devices.

The remainder of the book is devoted to the "phase angle method" which is the basis of this thesis. This method involves the least assumptions and is probably the most accurate developed to date. However, in this reference he cripples the method by applying unnecessary restrictions and manages to come out proving that the method is less accurate than his own method.

Consider a two machine system whose voltage magnitudes remain constant and where reactive power flows in such a manner as to keep the voltage constant.

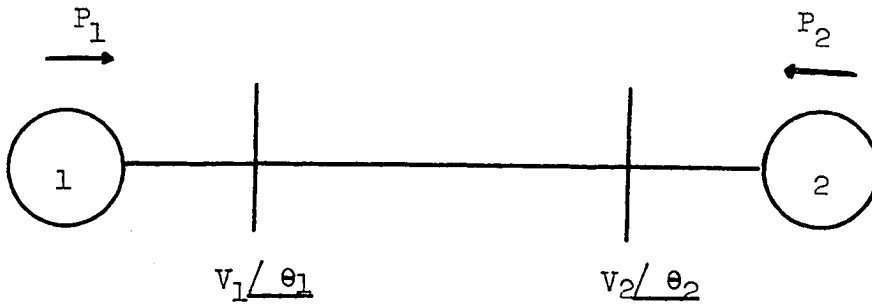

Figure 2. Two machine system without intermediate loads

The power angle equations may be written as:

$$P_1 = \frac{V_1^2}{Z_{11}} \sin \alpha_{11} + \frac{V_1 V_2}{Z_{12}} \sin (\theta_{12} - \alpha_{12}) \quad (5)$$

$$P_2 = \frac{V_2^2}{Z_{22}} \sin \alpha_{22} + \frac{V_2 V_1}{Z_{21}} \sin (\theta_{21} - \alpha_{21}) \quad (6)$$

where  $P_1$  = power at source 1

$P_2$  = power at source 2

$Z_{11}$ ,  $Z_{12}$ ,  $Z_{21}$ ,  $Z_{22}$  = absolute values of driving point and transfer impedances

$$\alpha_{11} = \tan^{-1} \frac{R_{11}}{X_{11}} \quad (7)$$

$$\alpha_{12} = \alpha_{21} = \tan^{-1} \frac{R_{12}}{X_{12}} \quad (8)$$

$$\alpha_{22} = \tan^{-1} \frac{R_{22}}{X_{22}} \quad (9)$$

$V_1$  = absolute value of voltage at source 1

$V_2$  = absolute value of voltage at source 2

$$\theta_{12} = \theta_1 - \theta_2 \quad (10)$$

where  $\theta_1$  = angle of voltage at source 1

$\theta_2$  = angle of voltage at source 2

If the line charging of the transmission line is lumped with the var requirements of the machine and if there are no intermediate loads or generators, then

$$Z_{11} = Z_{12} = Z_{21} = Z_{22} \quad (11)$$

$$\alpha_{11} = \alpha_{12} = \alpha_{21} = \alpha_{22} \quad (12)$$

It is intended to calculate the change in losses involved when the generation is swung between sources 1 and 2 by increasing the output of source 1 and decreasing the output of source 2.

The transmission losses are given by:

$$P_L = P_1 + P_2 \quad (13)$$

$$= \frac{V_1^2}{Z_{11}} \sin \alpha_{11} + \frac{V_1 V_2}{Z_{12}} \sin (\theta_{12} - \alpha_{12}) + \frac{V_2^2}{Z_{22}} \sin (\alpha_{22}) \quad (14)$$

$$+ \frac{V_2 V_1}{Z_{21}} \sin (\theta_{21} - \alpha_{21})$$

Assume that the system has changed to a new condition in which the angle between  $V_1$  and  $V_2$  increases to  $\theta'_{12}$  then

$$P'_L = P'_1 + P'_2 \quad (15)$$



The change in total losses is then given by

$$\Delta P_L = P'_L - P_L \quad (16)$$

The incremental loss which is required is given by dividing the change in loss by the change in generation of a given source when swinging generation between that one source and the other source. In this manner the value can be calculated as:

$$\frac{d P_{L_{1,2}}}{d P_1} = \frac{-2 \tan \theta_{12}}{\frac{X_{12}}{R_{12}} - \tan \theta_{12}} \quad (17)$$

He then develops this further to many machines and points out this can lead to a cumbersome expression. In general for  $n$  generators there will be  $n$  equations for  $\Delta P_n$ . However all of these except  $\Delta P_1$  will be zero giving rise to  $(n-1)$  equations. This gives rise to the set of equations:

$$\Delta P_j = \sum_{k \neq j}^n \frac{E_j E_k}{Z_{jk}} \cos(\theta_{jk} - \alpha_{jk}) \Delta \theta_{jk} \quad (18)$$

From these equations and the relations

$$\Delta \theta_{1k} = \Delta \theta_{12} + \Delta \theta_{2k} \quad (19)$$

$$\Delta \theta_{mn} = \Delta \theta_{mp} + \Delta \theta_{pn} \quad (20)$$

the various angles  $\Delta \theta_{jk}$  with  $j, k \neq 1, 2$  may be expressed in terms of  $\Delta \theta_{12}$

Knowing that  $\Delta P_{L_{1,2}} = \Delta P_1 + \Delta P_2$  divide  $\Delta P_{L_{1,2}}$  by  $\Delta P_1$  and an expression for  $\frac{d P_{L_{1,2}}}{d P_1}$  is obtained. Kirchmayer only develops this expression for

three machines and then finds the expression so cumbersome that he makes a number of mathematical assumptions which invalidate any accuracy inherent therein. His final conclusion is that the method does not have too much use.

Brownlee<sup>2</sup> in his paper did some of the original work on the above and also compared the results with results obtained by the B-Constant method of George and others. He pointed out that the other methods gave rise to considerable distortion of the incremental losses. As might be expected such comment did not go unchallenged. Early did some investigatory work and at the same time came up with his own version of Brownlee's method. He eventually agreed with Brownlee and also seriously questioned the accuracy of the B-constant method.

Glimn and Kirchmayer attacked Brownlee's method and questioned whether Brownlee was correct in his assumptions for loads located between machines. At the same time they corrected the B-constant method to remove some of the gross errors listed and naturally concluded that with their corrected method they were closer to the solution. Watson also studied Brownlee's method and found that the B-constant method gave more economic dispatch. However he did find better agreement between Brownlee's method and the correct value for the incremental losses. At the same time Ward and Hale conducted an investigation and started by challenging one of Brownlee's basic assumptions. This was that multiple transmission paths between any two plants may be represented by a single impedance. They objected strongly to this on the grounds that systems do have loops and that loads between other generators are not represented correctly by Brownlee. It was quite evident by this stage that there were two very decided factions on the subject, neither of whom would admit the others reasoning. Some further investigation was obviously needed in order to give a more accurate result.

Cahn<sup>4</sup> conducted a thorough investigation of Brownlee's work. As he stated in his introduction his purpose was to provide a more solid founda-

tion for Brownlee's results, showing some of the conditions which must be satisfied for their validity, to provide additional numerical examples of the successful use of Brownlee's theory, and to provide an extension of Brownlee's theory to give expressions for incremental and total losses which do not require knowledge of generator voltage phase angles. He pointed out that Brownlee had merely developed his formulas for two machines and by heuristic reasoning suggested they be applied to practical power problems. Cahn then went on and developed formulas for a multiple system from Brownlee's theory and applied these to two examples, one of which was a five-bus system and the other a seventeen-bus system. He calculated the losses by his method, the  $B_{mn}$  loss coefficients, the  $A_{mn}$  loss coefficients and the Kirchmayer loss formulas. The results showed that the Brownlee theory and his development thereof were applicable to practical electric systems, at least in those cases where all important voltage transmission is at the same voltage level. He states the formulas are about as accurate as the Kirchmayer  $B_{mn}$  formulas in most cases and furthermore he points out that his method involves considerably less computation. He finally concludes that the only exception to the accuracy of the Brownlee theory is where there is a wide disparity of the R/X ratios in the system. This it should be noted, is quite a qualifying phrase as in general there will be a wide disparity. In the enterprising discussion which followed, Brownlee was quite happy to find that Cahn had justified him while Kirchmayer and Glimm on the other hand were equally happy to look at the points where their formulas were best and to vindicate themselves. Kirchmayer stated that the errors resulted chiefly from the fact that neither Brownlee nor Cahn had correctly considered the effects of intermediate loads and generation when

there was a wide disparity in the R/X ratios of the lines. They furthermore stated that there did not have to be very much disparity before considerable errors were generated. They finally concluded that thanks to Cahn the errors in Brownlee's formula had been made clear. Cahn in reply to the discussion avoided these points entirely.

George<sup>11</sup> who had originated the B-constant method then re-entered the discussion with his old B-constant method brought up to date. George proposed a new method which he designed specifically for the digital computer. It is based on a principle which could not be utilized with data from an a-c calculating board power flow studies of losses because of limitations of accuracy in a-c board results. The method is extremely simple and appears cheap, at least for small and medium sized systems. It involves the following:

1. Assume a system with three sources. (It will have six B constants.) Set up six power flow studies with different loadings used on each source in each study. Read all the line currents.

2. Calculate the losses for each of the six power flow studies by the  $I^2R$  (current-resistance) method, using currents obtained in the studies just mentioned, and resistance values obtained from the impedance diagram.

3. Set up a system of six simultaneous equations in six unknowns, using the six B coefficients as six unknowns. Place the total calculated losses on the right hand side of each corresponding equation.

4. Solve the equations simultaneously by any method, preferably that of matrix inversion on a digital computer. The results should be the B constants.

George and E. D. Early did some work on this method and discovered it

to be highly accurate for the given power flow studies and that the B constants so derived would always fit the given generating conditions exactly, but would not fit other equally valid generating schedules. This method was developed as far back as 1953 but discarded then as too many of the equations were "ill conditioned". However since then methods have been developed for solving this type of equation and therefore the objection is no longer valid. "Ill conditioned" equations are such that small differences between large quantities are involved in the solution giving rise to gross errors. Eigenvalue theory can simplify this considerably. The objection to this system is that for large power systems too many load flow studies are needed. He suggests that further work is needed before definite conclusions can be reached on its application to large systems but that it does appear to have promise.

Lagerstrom<sup>22</sup> in his research reached the conclusion that the Brownlee phase angle method would be very accurate if some of the restrictions and other basic assumptions arising therefrom were changed. He first described the network as a set of transfer impedance magnitudes B and angles  $\beta$ . He described the fuel input versus generator output characteristic for each generator in the form of a power series. By differentiating this series he obtained the incremental rate. He then expressed the total system input as a function of the voltage magnitudes E and the phase angle differences throughout the system. He obtained his criteria for minimum input by setting the partial derivatives of the input with respect to the variables equal to zero. The only restriction which he placed was that the voltage profile in the system must be fixed ahead but he claimed this was not a very binding restriction. Therefore the voltages are not variable in seek-

ing the solution and the problem reduces to solving for the values of voltage phase angles which will make this partial derivative equal to zero. All the terms in the derivatives are of the form:

$$X_{ji} = E_j \frac{E_i}{B_{ji}} \sin(\beta_{ji} + \delta_{ji}) \quad (21)$$

with the restriction that  $j$  can never equal  $i$ . If the total system input is denoted by  $P_t$ , then the criteria can be summarized by:

$$\frac{\partial P_t}{\partial \delta_j} = \sum_{\substack{i=1 \\ i \neq j}}^n (X_{ji} - X_{ij}) = 0. \quad (22)$$

He solved these criteria by assuming a solution and iterating towards the final result. He assumed a set of phase angles and with these calculated the incremental rates. He evaluated the derivatives and by inspection of the sign of these determined which way his next solution should go. He applied this method to two and three machine systems. His method gave a lesser power input than any other methods to date. However even for three machines the expressions were cumbersome and some further work would need to be done before it could be adapted for large power system use. Convergence of the solution would also be a major problem and a method for obtaining rapid convergence was needed.

Brudenhall<sup>5</sup> discusses the TVA approach where they use an IBM 704 computer to preschedule their generation on an incremental cost basis. As there are a considerable number of stations in the system this adds to the complexity since many outside factors such as weather, downstream water supply to river cities, minimum river flow for navigation, hydro reservoir storage must be considered. The TVA is at present the most complex hydro-

thermal system to use a computer for prescheduling generation.

The fundamental equation for selection of generation on the basis of equal incremental costs of delivered power is:

$$\frac{dC}{dP_n} = \lambda \left( 1 - \frac{\partial P_L}{\partial P_n} \right) \quad (23)$$

where  $\frac{dC}{dP_n}$  = justifiable incremental generating cost at plant n

$\lambda$  = incremental cost of power delivered to a reference bus

$\frac{\partial P_L}{\partial P_n}$  = incremental transmission losses at plant n

In the TVA program this equation is solved in the form shown above. The related justifiable levels of generation at the various plants are determined from the incremental cost generating curves. In the computer solution iterative changes are made in  $\lambda$  until the total generating requirements are obtained.

One of the main differences between the TVA program and similar type programs is in the way the incremental transmission losses are computed, for which the TVA uses loss formula coefficients. Instead of assuming that all, or most, bus loads are conforming type loads, TVA computes a load for each bus. This treatment is especially desirable for the TVA system since about half of the total generation is delivered at near 100 per cent load factor during the 24 hour prescheduling period. Interchange of power with neighboring utilities is also a type of load that does not conform with other variable loads.

The equation for computing incremental transmission losses in the TVA program is:

$$\frac{\partial P_L}{\partial P_n} = 2 \sum_{m=1}^{m=48} P_m B_{nm} + 2 \sum_{j=1}^{j=104} R_j B_{nj} \quad (24)$$

where  $P_1$  to  $P_{48}$  = generation at buses 1 to 48

$R_1$  to  $R_{104}$  = load requirements, if any, at buses 1 to

104

B's = elements of loss formula coefficient matrix

Although these equations must be solved many times in the overall program, the second term is only solved once for each generating plant each hour. Thus, this more exact calculation of incremental losses is accomplished without an appreciable increase in computing time.

The basic computer program is best explained from a flow diagram as shown in figure 3. In this diagram, the four principal iterative loops of the overall program are shown. The first two relate to obtaining the generation schedule for a given hour. The third is used to get schedules for all 24 hours and the fourth is an iterative loop to adjust the water incremental costs ( $\gamma$ 's) to the amounts required for desired water use.

Several initial steps are required to set up the problem for an iterative solution. First, of course, the essential input information is read in. Next, the hourly bus loads are computed, along with the second terms of the Incremental Loss Equation for each of the 48 generating plants. The appropriate incremental generating cost curve is computed for each steam plant, along with hourly revisions when required. Also incremental discharge curves are interpolated for the 40 hydro plants. Finally, initial estimates of the  $\gamma$ 's for all hours are obtained from the results



of this computers program of the previous day.

The first loop of the flow diagram provides a generation schedule for a specific hour and a specific system  $\lambda$ . This is accomplished by the incremental loss equation and the appropriate equation for computing either the justifiable incremental generating cost of a steam plant, or the justifiable incremental discharge rate in the case of a hydro plant. The related generation level for a particular plant is then determined. Similar determinations are made for all plants, using the last computed P's in the incremental loss calculations. This process is repeated as required until a converged condition for the P's is obtained.

The second loop provides for iterative changes in system  $\lambda$ , until the sum of the generation scheduled in the first loop is equal to the total estimated load for the hour in question. Due to the large number of plants and to the use of step functions for hydro plants convergence is difficult to obtain.

The third loop of the flow diagram provides for the determination of generation schedule changes for all 24 hours. Since iterative changes are required in the hydro plant  $\gamma$ 's, many such 24 hour schedules are determined. The final hourly  $\lambda$ 's for a given 24 hour schedule of generation become the initial  $\lambda$ 's in the next such schedule of generation.

The fourth loop relates to the necessary adjustments of the 40 hydro plant  $\gamma$ 's. After each 24 hour schedule of generation has been computed, the sum of the hourly generations for each plant is obtained. Each total is compared with the corresponding total energy which is desired to be generated. It is possible with the program used to make the comparison on the basis of water rather than energy if preferred. If the total genera-

tion scheduled at a plant exceeds the desired amount, the  $\gamma$  at this plant is increased. Conversely if the total generation scheduled is less than the desired amount, the  $\gamma$  is decreased. As might be expected the convergence problem for this part is very difficult.

The net result is a very complex computer program. Over 5,000 instructions are required and the full 16,000 word memory of the computer is used. The computing time to prepare a single preschedule of generation is great, even for the fast IBM 704 computer. It ranges from 30 to 40 minutes and involves up to 40 million calculations.

In general for any solution of the network problem it is essential that the network be first described in terms of transfer and driving point impedances. For a large network this often was more of a problem than the optimum scheduling problem and with the advent of computers a number of people investigated the adapting of current methods to computer programming. Glimm and Kirchmayer<sup>12</sup> in 1955 brought out a very important paper on this subject. According to the American Standard Definition the driving point impedance at any pair of terminals of a network is the ratio of an applied potential difference to the resultant current at these terminals, all terminals being terminated in any specified manner. Similarly, the transfer impedance between any two pairs of terminals of a network is the ratio of a potential difference applied at one pair of terminals to the resultant current at the other pair of terminals, all terminals being terminated in any specified manner.

Driving point and transfer impedances as a circuit analysis technique have been widely used in load flow, short circuit, regulation, stability and transmission loss studies. In stability studies the driving point and

transfer impedances are measured with all the other terminals being short circuited while in other studies they are measured with all other terminals open and are then designated self and mutual impedances.

The self and mutual resistances of the transmission system are used in several methods of calculating the transmission loss formulas, and are usually obtained by measurements on the network analyzer and then transcribed to punched cards for calculations to be undertaken by a digital computer. Kirchmayer and Glimm in their paper describe several methods of calculating self and mutual impedances which have been successfully programmed for an automatic digital computer. These methods offer several distinct advantages over previous analog methods:

1. Greater accuracy
2. Lower cost
3. Very small setup time as general programming decks are available
4. Elimination of necessity of transcribing network analyzer results

to punched cards and associated time and possibility of error when these self and mutual impedances are required for digital circuit studies.

Before reviewing the digital methods it would be useful to summarize the network analyzer method. First a given bus is selected as a reference bus. The circuit performance is then described by the following equation:

$$E_{bus} = Z_{bus} I_{bus} \quad (25)$$

The self and mutual impedances ( $Z_{bus}$ ) which relate all bus currents and voltages are desired.

The procedure used is the following:

1. Remove all line charging capacitors, synchronous condensers,

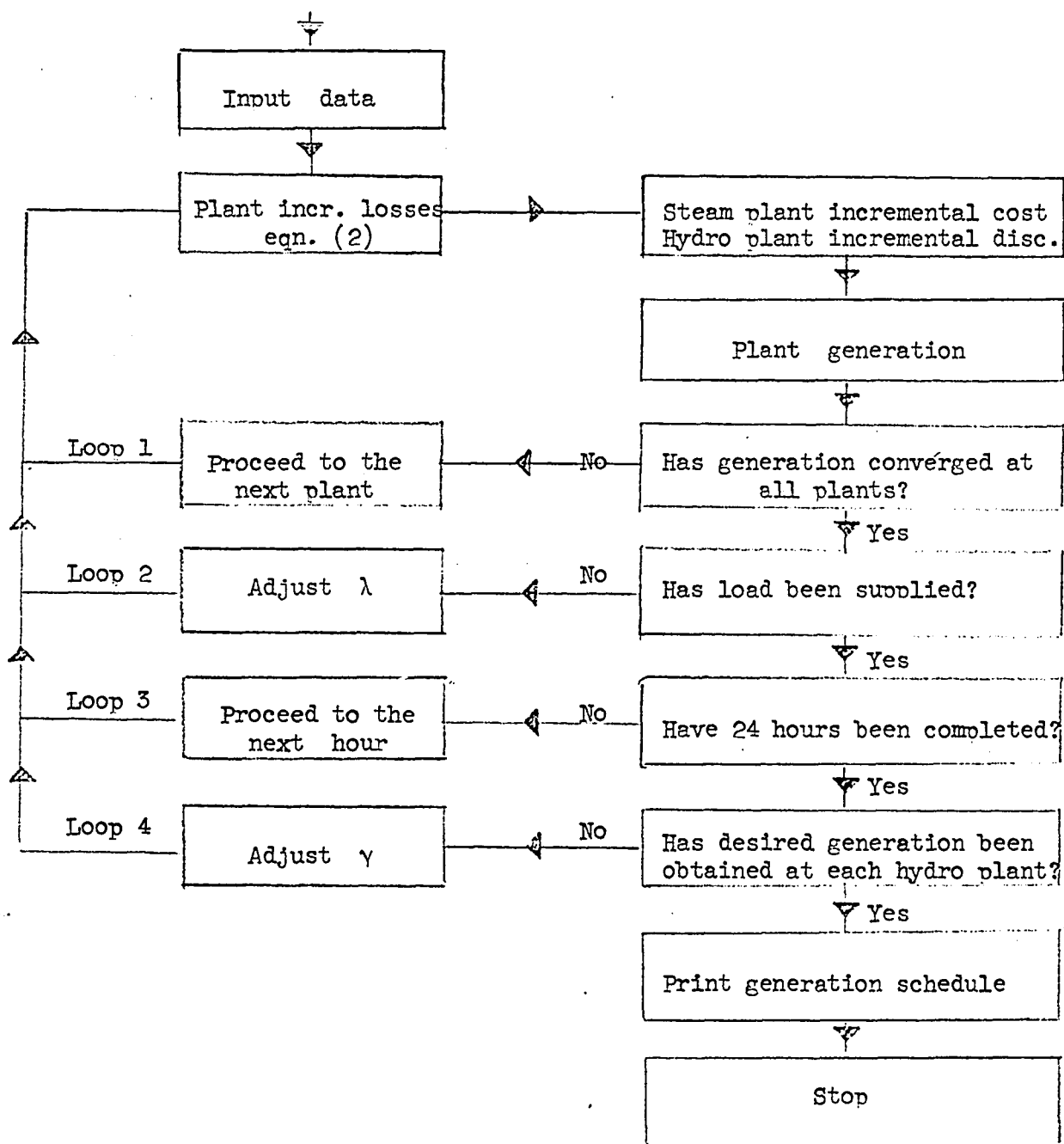

Figure 3. Computer flow diagram for generation prescheduling program.

loads and generators from ground.

2. Ground the reference
3. Impress a known current at a given bus and read the resulting voltages at all busses

The mutual impedance between the energized bus and each of the other busses is given by the ratio of the voltage at each of these busses to the impressed current. The self impedance of the energized bus is, of course, equal to the voltage at that bus divided by the impressed current.

This procedure is repeated with currents impressed, in turn, at each of the busses in the network. In this way a complete set of network mutual and self impedances is obtained.

Kirchmayer gives three methods for programming the computer. The first method is entitled "Matrix Analysis of Power System Network". This is the application of Kron's method on analysis of stationary networks. It applies matrix algebra to the equation:

$$E_{\text{branch}} = I_{\text{branch}} Z_{\text{branch}} \quad (26)$$

It solves this for Z by matrix methods which can be programmed relatively easily.

Method 2 is entitled "Self and Mutual Impedances from Impressed Currents". This is basically a digital replacement for the network analyzer method and consists of the following steps:

1. With the current at the reference bus grounded, impress a current of  $1 + j0$  at a generator or load bus in the network
2. Assume a current flow through the network from the energized bus to the reference
3. Compute in each branch the voltage resulting from the assumed

flows in step 2.

4. Compute the voltage acting through each loop by summing the branch voltage in each loop. Include the effects of off-nominal transfer ratios.

5. Compute the balancing currents required to make the summation of the voltages around each loop equal to zero

6. Superimpose the balancing flows determined in step 5 on the assumed flows of step 1.

7. Determine the branch voltages due to the exact flows in step 6

8. In terms of the branch voltages of step 7 determine the voltage at each bus in the network with respect to the reference

The voltages determined in step 8 are numerically equal to the open circuit impedances since the impressed current was  $1 + j0$ . In a manner similar to network analyzer procedure, the complete set of impedances may be determined by repeating steps 1 through 8 with currents impressed in turn at each of the network busses.

Method 3 is entitled "An Iterative Solution for Bus Voltages". This method acts on the principle that the sum of the currents to a bus is zero. It assumes a voltage profile and compares this with the resultant currents. It then corrects the profile until the voltages and the currents are in agreement. This method is probably the most complicated to use as many iterations may be necessary in a large system unless close to the correct profile can be chosen first time.

#### IV. THEORETICAL CONSIDERATIONS

##### A. Basic Theory

In order to develop a program for the optimum scheduling of generation for a power system network it first is necessary to describe the network in a suitable manner so that it can be used conveniently in the computer. For the initial solution the voltage profile in the system will be considered known and an attempt will be made to find the optimum generation schedule while allowing the generator voltage angles to vary. Then when this optimum has been obtained the magnitude of the voltages will be allowed to vary to determine the most suitable profile of voltage for the system. For this one voltage will be held fixed. The first voltage profile will be chosen by system considerations and by experience. It may be later necessary to change this owing to the inability of some generators to supply enough vars. In this case further computations will be necessary. It will also be assumed that the fuel input to the generators can be expressed as a function of the power output of the same and that this relationship will be independent of the var output. If this is not done it may prove impossible to schedule the var output of the generators to meet system requirements.

If we assume an  $n$  terminal network there will be  $\frac{n(n-1)}{2}$  transfer impedances. These transfer impedances can be represented as the  $Z$  in figure 4. The elements  $Y_1$  and  $Y_2$  are the shunt admittances and are obtained by combining the original network shunt capacitors, line charging capacitances, and loads. In the general case these two elements will not be equal.

It is normally easiest to express the watts and vars transmitted in terms of the network constants ABCD and a conversion from the constants of figure 1 will be given by the following equations:

$$A = 1 + ZY_r = A/\underline{\alpha} \quad (27)$$

$$B = Z = B/\underline{\beta} \quad (28)$$

$$C = (Y_1 + Y_2) + Z Y_1 Y_2 = C/\underline{\gamma} \quad (29)$$

$$D = 1 + Z Y_1 = D/\underline{\Delta} \quad (30)$$

If we designate  $E_s$  and  $E_r$  as the sending end and receiving end voltages for a transmission line, respectively, then we can write the power and the reactive power in terms of these voltages and the impedance constants by the following equations:

$$P_s = \frac{-E_s E_r}{B} \cos(\beta + \delta) + \frac{D E_s^2}{B} \cos(\beta - \Delta) \quad (31)$$

$$P_r = \frac{E_s E_r}{B} \cos(\beta - \delta) - \frac{A E_r^2}{B} \cos(\beta - \alpha) \quad (32)$$

$$Q_s = \frac{-E_s E_r}{B} \sin(\delta + \beta) + \frac{D E_s^2}{B} \sin(\beta - \Delta) \quad (33)$$

$$Q_r = \frac{-E_s E_r}{B} \sin(\delta - \beta) - \frac{A E_r^2}{B} \sin(\beta - \alpha) \quad (34)$$

Where  $\delta$  is the angle by which  $E_s$  leads  $E_r$ , the standard convention whereby lagging vars are considered positive is used.

We can represent a terminal of the network as in figure 5 and can write a power flow equation for this terminal.  $P_{L_i}$  represents the local load at the station,  $P_{g_i}$  the generated power from the generator to the bus



and  $P_{ij}$  the power transmitted from terminal  $i$  to terminal  $j$ . It should be pointed out that in defining  $P_{L_i}$  the sending end shunt admittances of all the lines terminating at  $i$  are combined with the actual admittance of the local load to give an equivalent local load. There is nothing inconsistent with this definition as it is the manner used in measuring transfer and shunt impedances on a network analyzer. In this all other terminals are short circuited and a voltage applied to terminal  $i$ . The transfer impedance is found by dividing the test voltage by the short circuit currents at each of the other terminals. Also the amount by which the current is drawn from the test generator exceeds the sum of the short circuit currents divided by the test voltage is the admittance of the equivalent local load  $P_{L_i}$ .

It will be presumed in this thesis that all self and mutual impedances are known as they can easily be calculated on an automatic digital computer by one of the methods listed by Glimm and Kirchmayer<sup>11</sup>.

$P_{g_i}$  denotes the generator output of plant  $i$ . The cost of operating this plant depends on a number of factors, chief of which are the fixed overheads, maintenance, depreciation, labor and interest costs. There are also variable charges due to the type fuel used, its cost and the efficiency of the plant. The relationship therefore between the plant output and the cost of the fuel input will not in general be linear but will vary considerably. There are a number of methods available for representing this relation, chief of which are one straight line, two straight lines, block jumps and power series. The last named has been used by Lagerstrom<sup>7</sup> and gave very satisfactory results. It is ideally suited to a computer as the computer can store the complete curve and can then always choose the cor-

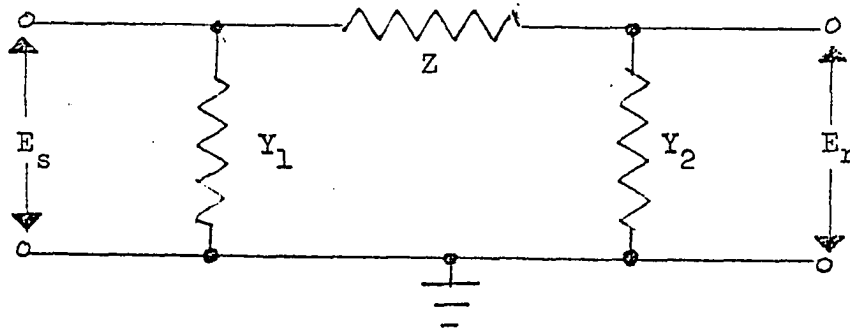

Figure 4. Equivalent circuit for reduced network between terminals 1 and 2.

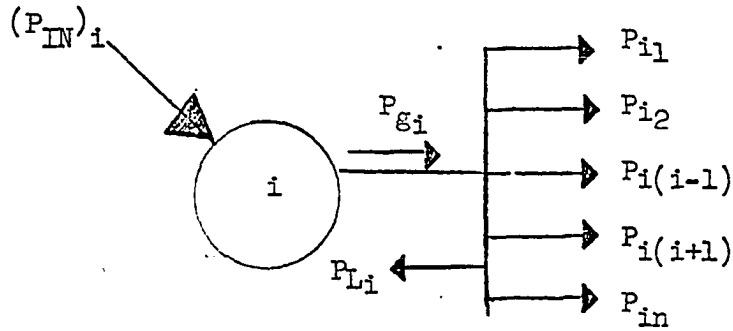

Figure 5. Schematic representation of power flows at terminal  $i$  of an  $n$ -terminal network.

rect value. The curve will certainly be accurate at the data points given and will be close to accurate at intermediate points. The more points on the curve, naturally, the more accurate the representation. The fuel input will be denoted by  $(P_{IN})_i$ , the capital subscripts and the parenthesis denoting fuel input and distinguishing it from power flow.

Returning to the power flow we designate  $P_{in}$  as the power transmitted through impedance  $B_{in}$  from plant  $i$  to plant  $n$ . It can be written in the following form:

$$P_{in} = -\frac{E_i E_n}{B_{in}} \cos(\beta_{in} + \delta_{in}) + \frac{D_{in} E_i^2}{B_{in}} \cos(\beta_{in} - \Delta_{in}) \quad (35)$$

where  $\delta_{in}$  is defined as  $\delta_i - \delta_n$ .

$$\text{It follows that } \delta_{ni} = -\delta_{in} \quad (36)$$

It should also be noted that the impedance angle of  $B_{in}$  is

$$\beta_{in} = \beta_{ni} \quad (37)$$

We designate the sum of all the line flows away from station  $i$  as  $P_i$ .

Then

$$P_i = P_{i1} + P_{i2} + P_{i3} + \dots + P_{in} \quad (38)$$

It is necessary to specify that  $P_{ii}$  is undefined for obvious reasons. This means that there will be  $(n-1)$  terms in the right hand side of equation 38. We have already defined the local load at station  $i$  as  $P_{L_i}$  therefore

$$P_{gi} = P_i + P_{L_i} \quad (39)$$

We recall that  $(P_{IN})_i$  is related to  $P_{g_i}$  by a functional relationship which for this thesis we will choose to be a power series relationship.

Therefore

$$(P_{IN})_i = C_i (P_{L_i} + P_i) \quad (40)$$

The total input to the system is given by the sum of all the  $(P_{IN})_i$  or

$$P_t = \sum_{i=1}^n (P_{IN})_i = \sum_{i=1}^n C_i (P_{L_i} + P_i) \quad (41)$$

If the value of  $P_t$  is to be a minimum then the partial derivative of it with respect to each and every variable will have to be equal to zero. Since  $P_t$  is a function of both  $E_j$  and  $\delta_j$  then the conditions for minimum  $P_t$  are

$$\frac{\partial P_t}{\partial E_j} = 0 \quad (42)$$

$$\frac{\partial P_t}{\partial \delta_j} = 0 \quad (43)$$

In general the values of  $E_j$  will be held within narrow limits. It will be assumed for the first run through that the voltage profile of the system will remain constant or that  $E_j$  will not change. Once an optimum has been obtained in that manner then  $E_j$  variations will be considered, and a true minimum obtained. By keeping  $E_j$  constant only a relative minimum with respect to  $\delta_j$  can be obtained.

It will therefore be first necessary to develop an expression for  $\frac{\partial P_t}{\partial \delta_j}$  and this can best be done by expanding the expression as follows:

$$\frac{\delta P_t}{\delta \delta_j} = \frac{\delta}{\delta \delta_j} \sum_{i=1}^n C_i (P_{L_i} + P_i) \quad (44)$$

$$= \sum_{i=1}^n \left[ C_i \frac{\delta P_i}{\delta \delta_j} + (P_{L_i} + P_i) \frac{\delta C_i}{\delta \delta_j} \right] \quad (45)$$

$C_i$  is not a function of  $\delta_j$  but unfortunately it is a function of  $P_{gi}$  which is in turn a function of  $\delta_j$ . Therefore it is necessary to write

$$\frac{\delta C_i}{\delta \delta_j} = \frac{dC_i}{dP_{gi}} \cdot \frac{\delta P_{gi}}{\delta \delta_j} \quad (46)$$

but 
$$\frac{\delta P_{gi}}{\delta \delta_j} = \frac{\delta P_i}{\delta \delta_j}$$

since  $P_{L_i}$  is independent of  $\delta_j$ .

The partial derivative of  $P_t$  may now be written

$$\begin{aligned} \frac{\delta P_t}{\delta \delta_j} &= \sum_{i=1}^n \left[ C_i \frac{\delta P_i}{\delta \delta_j} + P_{gi} \frac{dC_i}{dP_{gi}} \cdot \frac{\delta P_i}{\delta \delta_j} \right] \\ &= \sum_{i=1}^n \frac{\delta P_i}{\delta \delta_j} \left[ C_i + P_{gi} \frac{dC_i}{dP_{gi}} \right] \\ &= \sum_{i=1}^n \xi_i \frac{\delta P_i}{\delta \delta_j} \end{aligned} \quad (47)$$

where  $\xi_i$  is the sum in brackets. This  $\xi_i$  is the incremental production rate of station  $i$  as defined in the literature.

The proof of the preceding statement can be ascertained if the rela-

relationship between  $(P_{IN})_i$  and  $P_{gi}$  be differentiated:

$$(P_{IN})_i = C_i P_{gi} \quad (48)$$

$$\xi_i = \frac{d(P_{IN})_i}{d P_{gi}} = C_i + P_{gi} \frac{dC_i}{dP_{gi}} \quad (49)$$

The next step is to expand  $\frac{\delta P_t}{\delta \delta_j}$  so that a technique for detecting the minimum value can be obtained. This will first be done for a three machine system as this is used for the example later in the thesis. Afterwards it will be expanded to a n machine system when the method becomes evident. For a three machine system consider  $\frac{\delta P_i}{\delta \delta_j}$  letting  $i = 1, 2, 3$  in turn and  $J = 1$ . The expansion is:

$$\frac{\delta P_1}{\delta \delta_1} = \frac{E_1 E_2}{B_{12}} \sin(\beta_{12} + \delta_{12}) + \frac{E_1 E_3}{B_{13}} \sin(\beta_{13} + \delta_{13}) \quad (50)$$

$$\frac{\delta P_2}{\delta \delta_1} = - \frac{E_2 E_1}{B_{21}} \sin(\beta_{21} + \delta_{21}) \quad (51)$$

$$\frac{\delta P_3}{\delta \delta_1} = - \frac{E_3 E_1}{B_{31}} \sin(\beta_{31} + \delta_{31}) \quad (52)$$

A similar set of derivatives can be obtained for  $j = 2, 3$ . Note that the terms are all negative except when  $i = j$  in which case the term is positive. This follows from  $\delta_{in} = -\delta_{ni}$ . Furthermore there is but one term relating each plant  $j$  to the reference plant  $i$ .

It is now possible to set out all the derivatives for  $j = 1, 2, 3$  and

to equate them to zero:

$$\begin{aligned} \frac{\delta P_t}{\delta \delta_1} = 0 = & \xi_1 \left[ \frac{E_1 E_2}{B_{12}} \sin(\beta_{12} + \delta_{12}) + \frac{E_1 E_3}{B_{13}} \sin(\beta_{13} + \delta_{13}) \right] \\ & - \xi_2 \frac{E_2 E_1}{B_{21}} \sin(\beta_{21} + \delta_{21}) - \xi_3 \frac{E_3 E_1}{B_{31}} \sin(\beta_{31} + \delta_{31}) \end{aligned} \quad (53)$$

$$\begin{aligned} \frac{\delta P_t}{\delta \delta_2} = 0 = & -\xi_1 \frac{E_1 E_2}{B_{12}} \sin(\beta_{12} + \delta_{12}) + \xi_2 \left[ \frac{E_2 E_1}{B_{21}} \sin(\beta_{21} + \delta_{21}) \right. \\ & \left. + \frac{E_2 E_3}{B_{23}} \sin(\beta_{23} + \delta_{23}) \right] \end{aligned} \quad (54)$$

$$- \xi_3 \frac{E_3 E_2}{B_{32}} \sin(\beta_{32} + \delta_{32})$$

$$\begin{aligned} \frac{\delta P_t}{\delta \delta_3} = 0 = & -\xi_1 \frac{E_1 E_3}{B_{13}} \sin(\beta_{13} + \delta_{13}) - \xi_2 \frac{E_2 E_3}{B_{23}} \sin(\beta_{23} + \delta_{23}) \\ & + \xi_3 \left[ \left( \frac{E_3 E_1}{B_{31}} \sin(\beta_{31} + \delta_{31}) + \frac{E_3 E_2}{B_{32}} \sin(\beta_{32} + \delta_{32}) \right) \right] \end{aligned} \quad (55)$$

It will now be necessary to solve these equations simultaneously to yield the desired minimum value of  $P_t$ .

As equations 53, 54, and 55 are too cumbersome to repeat at length a simplification will be made.

Let

$$X_{12} = \xi_1 \frac{E_1 E_2}{B_{12}} \sin(\beta_{12} + \delta_{12}) \quad (56)$$

$$X_{13} = \xi_1 \frac{E_1 E_3}{B_{13}} \sin(\beta_{13} + \delta_{13}) \quad (57)$$

$$X_{21} = \xi_2 \frac{E_2 E_1}{B_{21}} \sin(\beta_{21} + \delta_{21}) \quad (58)$$

$$X_{23} = \xi_2 \frac{E_2 E_3}{B_{23}} \sin(\beta_{23} + \delta_{23}) \quad (59)$$

$$X_{31} = \xi_3 \frac{E_3 E_1}{B_{31}} \sin(\beta_{31} + \delta_{31}) \quad (60)$$

$$X_{32} = \xi_3 \frac{E_3 E_2}{B_{32}} \sin(\beta_{32} + \delta_{32}) \quad (61)$$

Rewriting the expression for  $\frac{\delta P_t}{\delta \delta_j}$  using the above form gives

$$\frac{\delta P_t}{\delta \delta_1} = X_{12} + X_{13} - X_{21} - X_{31} = 0 \quad (62)$$

$$\frac{\delta P_t}{\delta \delta_2} = -X_{12} + X_{21} + X_{23} - X_{32} = 0 \quad (63)$$

$$\frac{\delta P_t}{\delta \delta_3} = -X_{13} + X_{31} - X_{23} + X_{32} = 0 \quad (64)$$

These equations can then be written in the form:

$$(X_{12} - X_{21}) - (X_{31} - X_{13}) = 0 \quad (65)$$



$$-(x_{12} - x_{21}) + (x_{23} - x_{32}) = 0 \quad (66)$$

$$(x_{31} - x_{13}) - (x_{23} - x_{32}) = 0 \quad (67)$$

The original equations 53, 54, and 55 have now been written as a set of three linear homogeneous equations in three unknowns. Since the rank of the matrix of the coefficients of these unknowns is one less than the number of equations then there will be an infinity of solutions other than the trivial one.

Considering the trivial solution first we arrive at results similar to those obtained by Brownlee for a two machine system. In this case we could write

$$(x_{12} - x_{21}) = (x_{31} - x_{13}) = (x_{23} - x_{32}) = 0 \quad (68)$$

or expanding it in full:

$$\xi_1 \sin(\beta_{12} + \delta_{12}) = \xi_2 \sin(\beta_{21} + \delta_{21}) \quad (69)$$

$$\xi_2 \sin(\beta_{23} + \delta_{23}) = \xi_3 \sin(\beta_{32} + \delta_{32}) \quad (70)$$

$$\xi_3 \sin(\beta_{31} + \delta_{31}) = \xi_1 \sin(\beta_{13} + \delta_{13}) \quad (71)$$

This is somewhat paradoxical as  $\frac{\xi_1}{\xi_2}$  and  $\frac{\xi_2}{\xi_3}$  can be got from 69 and 70 and yet 71 has not even been considered. This particularly when there is a new variable in 71, namely  $\beta_{13}$ . We are therefore forced to discard the trivial solution, Brownlee notwithstanding, and to consider only other solutions.

As it would be very difficult to start with equations 65, 66, and 67

and work back towards  $\delta_1$ ,  $\delta_2$ , and  $\delta_3$  we will start by assuming  $\delta_j$  and working forward. We will then consider the deviation of each of the quantities in 65, 66 and 67 from zero and correct our deltas accordingly. It would seem logical that if  $\frac{\partial P}{\partial \delta_j}$  should turn out to be negative for example, then an increase in the angle would be indicated and vice versa.

To summarize, first for the entire system determine the transfer impedances among all possible pairs of generator terminals and denote any interconnection points as generator terminals. This may be done either by setting the system up on a network analyzer or by a computer program selected from those available for the purpose. Next determine the shunt load impedances to be applied to these terminals and also find the power which they will demand from the network. Then assign initial values of voltage phase angles to the system. These may be chosen arbitrarily but ideally should be close to the expected solution. The voltage magnitude profile of the system is presumed known.

The power flow away from each terminal is then calculated as in equation 35. This is the power flow along the transmission lines away from that terminal. Upon combining this with the local load the total power output of the generator is obtained. The total power input is now obtained by adding the sum of the inputs to all the machines of the system. Taking the partial derivatives of the total power with respect to each phase angle and setting all of these derivatives equal to zero will give the conditions for minimum input. These will be the equations which the computer must solve.

### B. Computer Approach to Solution

The computer approach to the problem solution is an iterative approach and is best illustrated by a flow chart such as shown in figure 6. The first stage is to input the data. This consists of the voltage magnitudes and phase angles, the local load at the generators, the impedance magnitudes and angles. The voltage profile will have been selected already and will be based on experience. The voltage angles which are the variables in the solution are not really necessary as the computer is capable of arriving at a solution no matter what set of voltage angles it starts with. However, the number of iterations is lessened somewhat if the first trials are in the neighborhood of the final answers. Therefore, whether the set of voltage phase angles to start the iterations from is included or not depends on the mood of the system engineer. The local loads will be determined by system requirements and will be known at the start of the problem. The impedance magnitudes and angles will also be known having been determined as outlined earlier in this work. A separate computer program can be used for these. It could also be arranged that this program be incorporated into the solution of this problem so that if the voltages were to be changed in the system then the impedances would be recalculated automatically and the corrected versions used in this program. This refinement could be added with very little extra trouble.

The next step is for the computer to compute the angular differences between each and every pair of plants. It will then store these for further use. It then will compute  $P_{ij}$  according to equation 35 and store these. By adding  $P_{L_i}$  to each sum  $P_i$ , it will compute  $P_{gi}$ . There will be

three such values. From this it can evaluate  $P_t$  which is a function of  $P_{gi}$  and is given by a power series relationship or other relationship if such should be preferred.

The incremental rates can next be calculated as these are functions of  $P_{gi}$  alone. It could be noted here that if the results for equal incremental rates are desired, this can be easily done by setting  $\delta_{ij} = 0$ . The next step is the evaluation of the  $X_{ij}$  factors and these are obtained from equations 56 through 61. Finally they are combined as per equations 65, 66 and 67.

In general the values for the left hand sides of equations 65, 66 and 67 will not be zero. For convenience we will designate

$$Z_1 = \frac{\partial P_t}{\partial \delta_1} \quad (72)$$

$$Z_2 = \frac{\partial P_t}{\partial \delta_2} \quad (73)$$

$$Z_3 = \frac{\partial P_t}{\partial \delta_3} \quad (74)$$

However the sum  $Z_1 + Z_2 + Z_3$  will always be zero. This means that at least one of them must be positive. In general two will be of one sign and one of the opposite sign. The machine then by selection will sense which of the three quantities is alone in its sign notation. If this should be  $Z_1$  then  $\delta_1$  will need correction. If  $Z_2$  then  $\delta_2$ , and if  $Z_3$  then  $\delta_3$ . The correction will be of the opposite sign to that of  $Z_i$ . Thus if  $Z_i$  is positive,  $\delta_i$  will be decreased. If  $Z_i$  should be negative,  $\delta_i$  will be increased.

At this stage a critical decision has to be made. If an over cor-

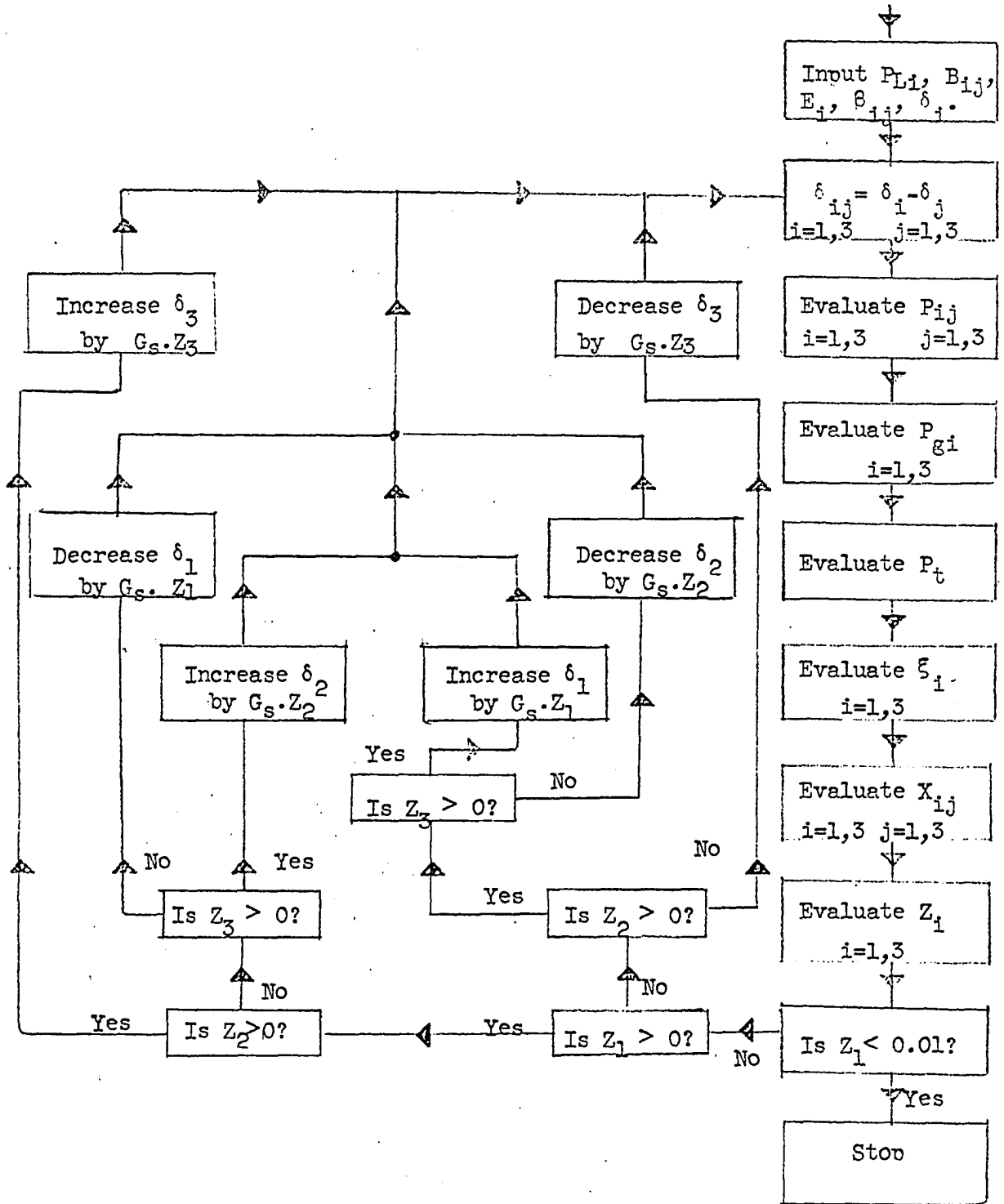

Figure 6. Flow chart 1.

rection is made then on the next run through the  $Z_1$  will be farther from zero and in general over correction will lead to instability and a rapidly diverging solution. On the other hand if the correction is too small, then too many iterations will be necessary to arrive at the solution. The choice of the correction factor  $G_s$  is consequently of the utmost importance. This will be commented on further at a later stage in this work and the effects of this factor considered.

Assuming that the correct correction is applied, then the succeeding values of  $Z_1$ ,  $Z_2$ , and  $Z_3$  will be closer to zero. A stop to the iteration process can be made when either the magnitude of one of them is small enough or the decrease in total input power becomes negligible due to each succeeding correction. It is recommended that once the magnitude of  $Z_i$  gets to a predetermined value, this will be sufficient indication of the closeness of the solution.

At this stage when the computer finishes its iterations, it will have found values of  $\delta_i$  which give the minimum power input to the system while holding  $E_i$  constant. However, this will not be an absolute minimum and in order to find this or as close to it as is practicable, a further program is necessary. The flow chart for this is shown in figure 7.

The difference here is that the computer will iterate through a number of successive voltage profiles optimizing the power input for each profile. For this the lowest voltage in the system is considered fixed or if this is not possible then one voltage will have to be considered fixed. Otherwise it would be clear that by lifting all voltages indefinitely the less would be the power input to the system. This is impracticable in a normal system and the purpose of this thesis is to find a solution for a

practical system. Accordingly, having fixed one voltage, the computer will iterate around the other voltages starting with about 80% of the voltage profile used in the first flow chart and going up in successive jumps to about 120%. If at any time on the way upwards it finds it has passed the minimum, then it will stop and proceed to the next profile. When finished it will print out the optimum power input and generation schedule for each profile and the most desirable profile can be selected. There is not too much point in printing out the absolute optimum alone, as in practice this may be undesirable from a system point of view. In view of the fact that the digression from the minimum is relatively small for considerable voltage changes, it would be more desirable from an operating point of view to have a number of choices available. One of these would then be selected by the dispatcher.

If the absolute minimum for all the voltage profiles is chosen, then automatically the correct values of the phase angles will also have been calculated and will be printed. The second program may seem unnecessary but in the author's view it is desirable to get to the relative minimum first as if the computer starts with no voltage magnitude and no voltage angle, then the number of iterations to reach the desired results will become excessive. The purpose of this thesis is to find a rapid method of arriving at the solution rather than a general method. It is believed that the method shown will arrive at the solution more rapidly than starting everything from zero.

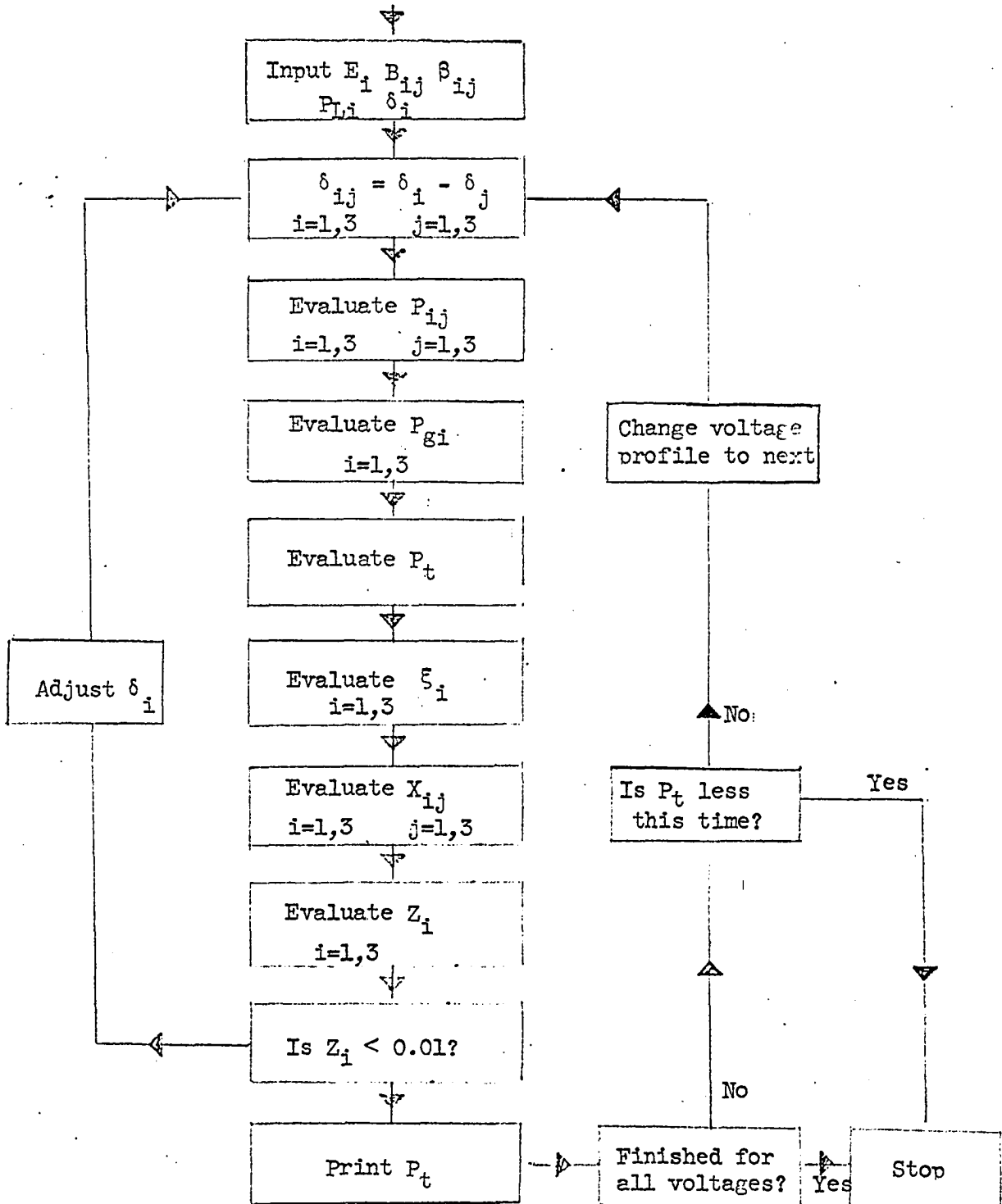

Figure 7. Flow chart 2.



## C. Generalization for More Than Three Machines

The solution for a large system with  $n$  machines is the application of equations 53, 54 and 55 which can be extended to the general form:

$$\frac{\partial P_t}{\partial \delta_j} = \sum_{\substack{i=1 \\ i \neq j}}^n (X_{ji} - X_{ij}) = 0 \quad (75)$$

where

$$X_{ji} = \xi_j \frac{E_j E_i}{B_{ji}} \sin(\beta_{ji} + \delta_{ji}) \quad (76)$$

The computer flow chart will be that shown in figure 8 and the method of solution will be similar to that for three machines. The convergence factor  $G_s$  will become more important as the number of machines grows greater and the accurate choice of this will speed up the solution.

If the number of machines becomes very large it may be insufficient to stop the iteration when the magnitude of  $Z_1$  becomes less than a predetermined value and instead it may prove necessary to only stop the iteration when a number of the  $Z_1$  become less than this value. This predetermined value can only be fixed by experience with the system and will be found by experiment.

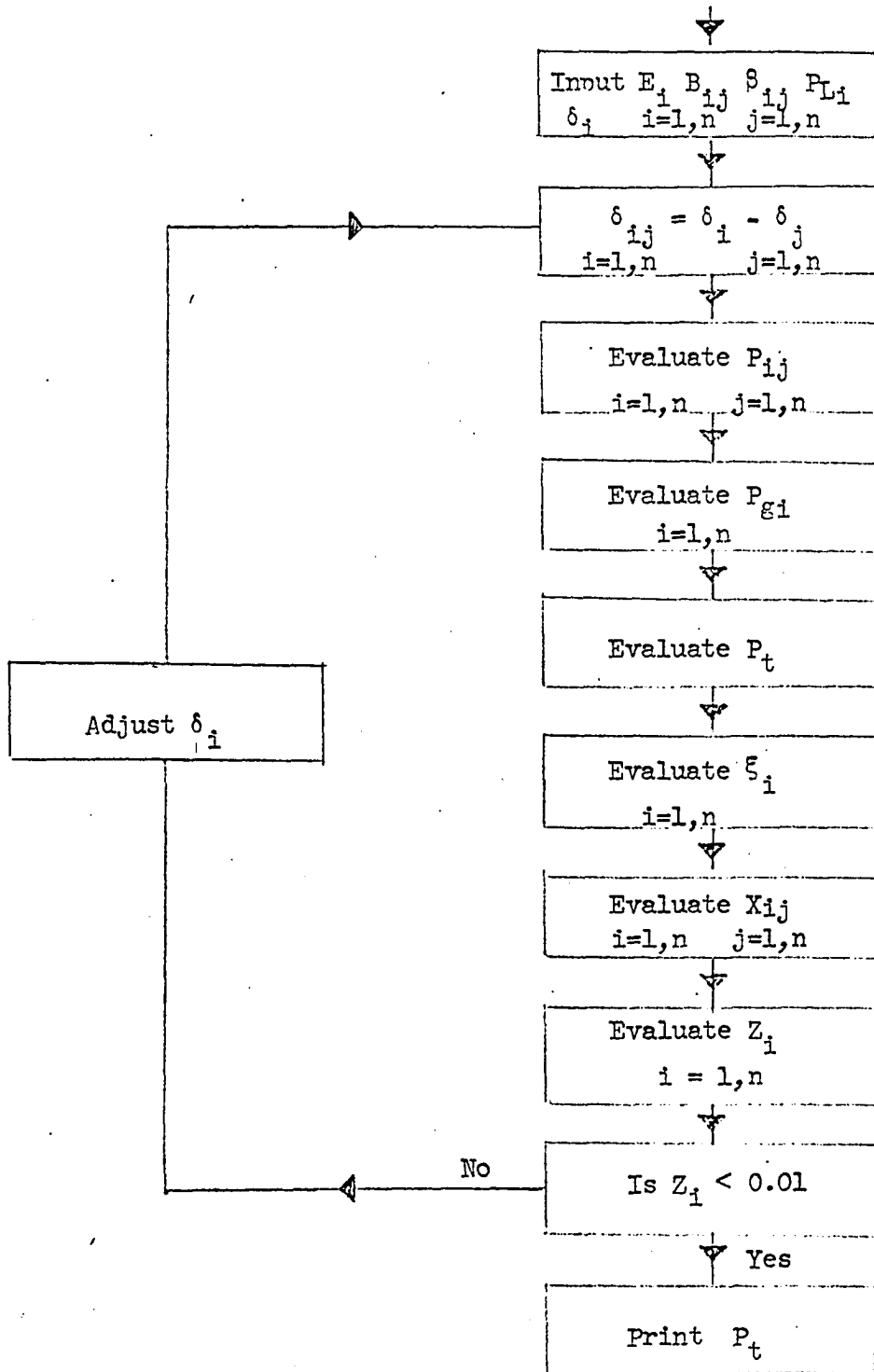

Figure 8. Flow chart for n-machine system.

## V. EXPERIMENTAL RESULTS

### A. Preparation of Data

In order to prepare the system for solution both the transfer impedances or admittances must be determined as well as the voltage profile. The older method of determining the transfer impedances was on the network analyzer and this would be quite satisfactory if limited accuracy only was desired. The network must be considered passive for this. First the system is balanced for a given load condition and all loads trimmed to desired levels of watts and vars. The transfer impedances are then the ratios of the various generator voltages applied one at a time to the short circuit currents resulting at all the other generator terminals in the network. It should be pointed out that by using this method, each impedance will be calculated twice thus giving a check on the mathematics.

If more accuracy is desired, then the computer itself can be used for determining the transfer impedances. The methods for doing this have been discussed in the review of the literature. Any of the three methods listed would prove satisfactory. The calculation of the impedances by the computer is to be preferred as when the voltage profile is changed later to give optimum power input, the impedances will have to be recalculated and the computer can do this automatically if the program already exists. In general it may be said that the network analyzer is no longer satisfactory for calculating the transfer impedances. In this thesis in the examples used, the impedances are already presumed to have been calculated.

The local loads will also need to be known as while they are not evident in the calculation of the partial derivatives, they are present in

the incremental rate calculations. It is normal that the larger the local load the higher the incremental rate of that generator and the less economical it will be to transmit power away from that machine to other machines of the system.

The fuel input data must also be calculated in order to solve the problem. In order to do this the cost input to the plants must be known as a function of power output. In general these curves are non linear and can be approximated by either a series of straight lines or a power series. Lagerstrom has shown that the power series method gives very good results and for computer use it will be even more satisfactory.

In this work the power series method is used. In general, there will be as many terms as there are data points for its determination, including a constant term to represent the input at zero output. As the magnitude of the terms diminishes with increasing order of power output, it will be generally found sufficient to include terms only up to and including the third order. This method of representation will always give the output accurately for any of the data points, and for points in between will give it to a high degree of accuracy. Naturally, the more data points given the more accurate will be the representation.

It is recommended that for still greater accuracy in this representation the whole curve be programmed in the computer which can be done with very little difficulty. This will remove the last vestiges of error inherent in the representation.

Once the input output curve has been represented, the incremental rate of that plant can be determined by differentiating this curve. The power series method makes this somewhat easier. In the power series method

the incremental rate curve of any plant will then always be another curve of order one less than the input-output curve.

The system chosen for this thesis is shown in figure 9. The input-output and incremental rate curves are shown in figure 10. It is interesting to note that while plant 1 has the highest no load input, it has the lowest incremental rate curve. This proves that not too much information can be gleaned from the input curve on how to apportion the load and that the incremental rate curve is of the utmost importance in calculating the load sharing.

The expressions for input and incremental rate as functions of plant output for the three plants used in the example are:

$$(P_{IN})_1 = 2.28 + 0.520 P_{g1} + 0.380 P_{g1}^2 + 0.040 P_{g1}^3 \quad (77)$$

$$(P_{IN})_2 = 1.59 + 0.75333 P_{g2} + 0.440 P_{g2}^2 + 0.02667 P_{g2}^3 \quad (78)$$

$$(P_{IN})_3 = 1.04 + 1.16333 P_{g3} + 0.84002 P_{g3}^2 - 0.01333 P_{g3}^3 \quad (79)$$

$$\xi_1 = 0.520 + 0.760 P_{g1} + 0.120 P_{g1}^2 \quad (80)$$

$$\xi_2 = 0.75333 + 0.880 P_{g2} + 0.080 P_{g2}^2 \quad (81)$$

$$\xi_3 = 1.16333 + 1.68003 P_{g3} - 0.040 P_{g3}^2 \quad (82)$$

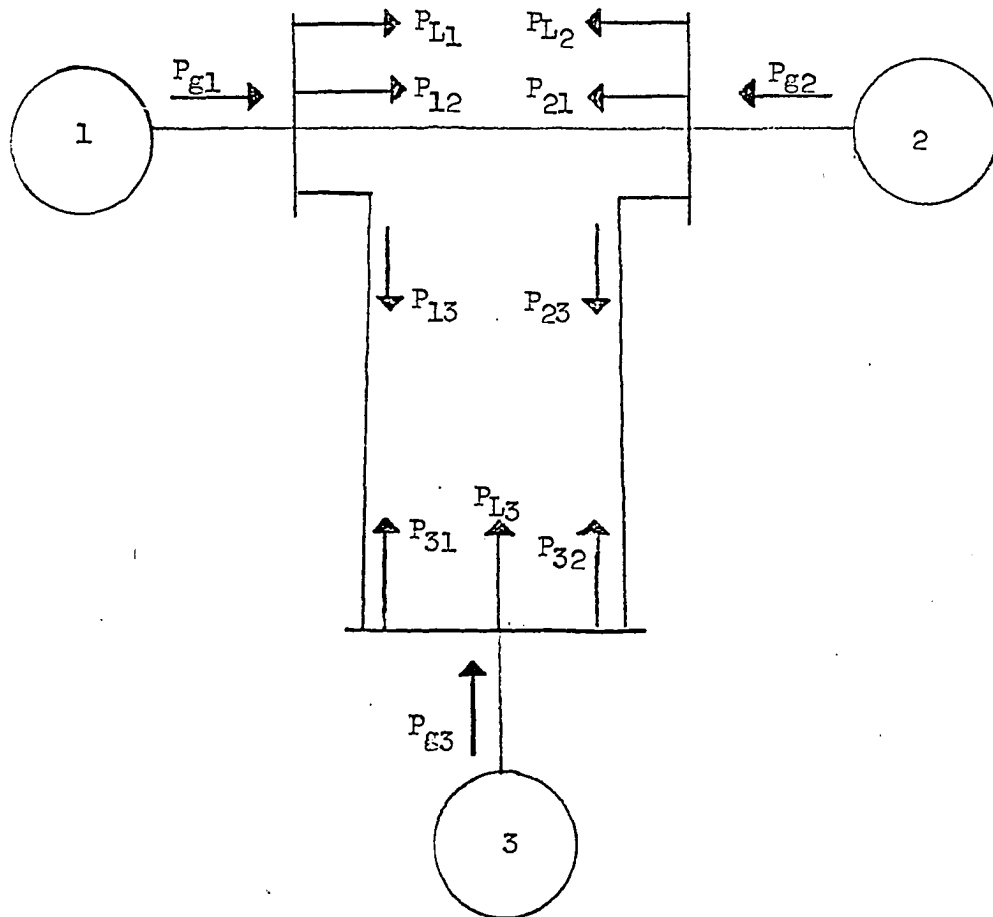

$$B_{12} = 0.10 + j 0.20 = 0.22361 \angle 63^{\circ} 26'$$

$$B_{23} = 0.15 + j 0.25 = 0.29155 \angle 59^{\circ} 2'$$

$$B_{31} = 0.20 + j 0.30 = 0.36056 \angle 56^{\circ} 19'$$

Figure 9. Three-machine system.

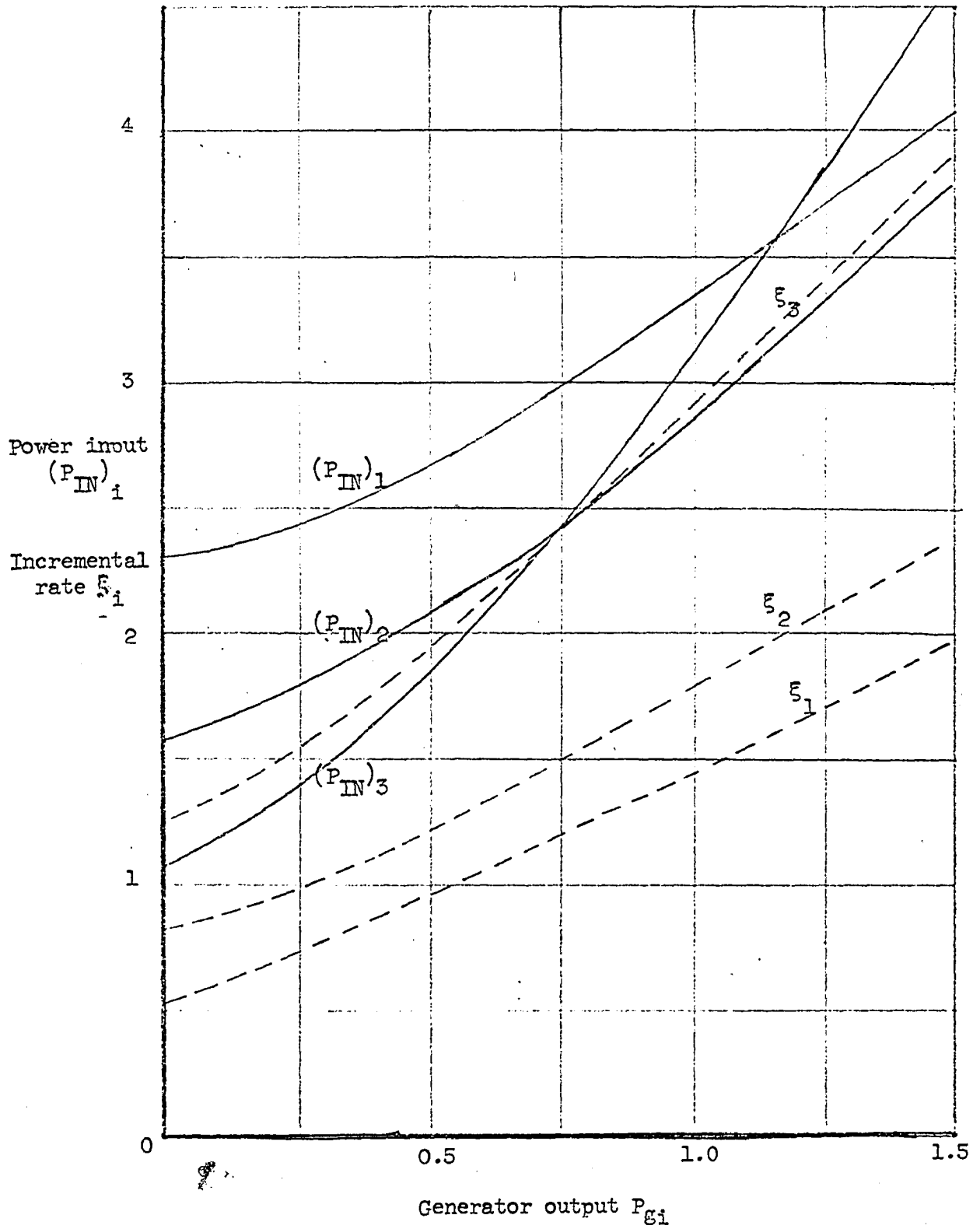

Figure 10. Input-output and incremental rate curves.

## B. Preparation of the Computer Program

The computer used in this thesis was the Iowa State University Cyclone Digital Computer. This is a relatively slow machine and can work in any of a number of languages, such as Eerie, Sar, Algol, Fortran, etc. For the type of work in this thesis Fortran language was used as it was believed to be the best suited. This was borne out at a later stage when a typical Fortran program was about 120 instructions long. The computer then proceeded to compile its own Eerie Program from this and a check showed the length of this program to be over 1,000 instructions thus giving evidence that Fortran is considerably less cumbersome. The Fortran program has other advantages in that it is much easier to prepare and it is quicker to find mistakes in it or to change it. The programs used in this work are all given in the appendix.

The solution to the problem by the computer is in two steps. First for a given voltage profile - the magnitudes alone are fixed - the computer will calculate the optimum phase angles of the various generators for minimum system input. Then having obtained these phase angles, it will let the magnitude of the voltages vary and calculate a number of different profiles which are either at the minimum input point or very close to it. One such profile will have the absolute minimum input but this may not be practicable in terms of system physical realities, hence the calculation of a number of such profiles with the one to be used being left for an operator to determine such choice being based on both the physical capabilities of the system as well as experience.

The flow chart for the solution to the first step is given in figure 7. The input data will consist of the voltage magnitudes for the genera-



tors, the transfer impedances in both magnitude and angle, the local loads at each station and an initial set of phase angles for the computer to start from. The voltage data will be the magnitudes of the voltages at the generator buses and these should be known. The transfer impedances will have been found by a previous program and are therefore considered known. However, if the voltage profile should be changed later, then this in turn will necessitate the recalculation of the transfer impedances and ideally this should be an integral part of the program. To avoid complications in this thesis, the transfer impedances were considered fixed and unchanging. The initial set of voltage phase angles is not critical. The machine is quite capable of starting with all values zero, but it is somewhat quicker if it can be fed values close to the actual values. This is not too difficult to do as for most systems the range of phase angles is known.

The next step is to calculate the phase angular differences between each pair of machines. As there are three machines in the example, this will give rise to a nine element matrix with three elements zero. This is the application of equation 36.

Applying equation 35 the machine will calculate the various power flows between each pair of generators. The summation of the power flows from any one generator will give the total power flow away from that generator. Addition of the local load to this will give the total power output from any one generator. This power output from each generator  $P_{gi}$  will give rise in this example to a three element matrix.

The computer will now make recourse to the input-output curves for

each generator and calculate the input to each machine. Addition of the inputs to all the machines will give the total power input to the system. It will then proceed to calculate the incremental rates for each generator making use of equations 80, 81 and 82.

It is now possible to calculate the various  $X_{ij}$  from equation 76 and there will be 6 of these since  $X_{ij}$  is not defined for  $i = j$ . Grouping these  $X_{ij}$  according to equations 65, 66 and 67, the various  $Z_i$  will be calculated.  $Z_i$ , it will be recalled, represents the partial derivative of the total input power with respect to the phase angle  $\delta_i$ . In the ultimate solution this will be zero or sufficiently close to being neglected.

As the sum of the three  $Z_i$  will always be exactly zero, at least one of them will be positive and one negative. There will be two  $Z_i$  of one sign and the third of the opposite sign. This third  $Z_i$  will also have the largest magnitude. The computer must now find the  $Z_i$  which has the largest magnitude and it proceeds to do this by a process of elimination. The computer is capable of sensing whether a quantity is positive, zero or negative and acting on three different instructions, one for each sense.

The computer first inspects  $Z_1$ . If it finds this to be zero, which is most unlikely since the problem is rarely solved the first time through, then it will conclude that the angles chosen were correct and no further work is necessary. It should be pointed out that even if  $Z_1$  be zero, this does not necessarily mean that  $Z_2$  and  $Z_3$  are zero. However, in a three machine system it will be found that if one of the  $Z_i$  be zero, then the other two will be either zero or very close to zero. In a system of more than three machines this condition will not be sufficient and it will be necessary to inspect at least half of the  $Z_i$  and it should not be concluded

that the problem is solved unless at least half the  $Z_i$  are zero or sufficiently close to it.

In a practical problem the computer on sensing  $Z_1$  will find it to be either negative or positive. If it be positive, it proceeds to  $Z_2$  which will be either negative or positive. If this be positive, then  $Z_3$  is negative and the computer must increase  $\delta_3$ . If it is negative, then it must proceed further to  $Z_3$ . If this is negative then  $\delta_1$  must be decreased. If  $Z_3$  is positive,  $\delta_2$  must be increased as this combination implies  $Z_2$  is the only negative quantity. In such a manner it searches through all possible combinations of the  $Z_i$  and when it finds which  $Z_i$  is alone in its sign, it changes that  $\delta_i$ . If this  $Z_i$  be negative, it increases  $\delta_i$ . If the  $Z_i$  be positive, it decreases  $\delta_i$ . Ideally this increase or decrease would be such that on the next iteration  $Z_i$  would be exactly zero. In practice this will not happen and the correction will be either too much or too little. The amount of the correction is therefore very important.

The critical stage of the solution is now entered.  $\delta_i$  is changed by either the addition or subtraction of  $Z_i$  multiplied by a quantity known as the convergence factor  $G_s$ . If this convergence factor is too large, an over correction will occur, the next solution will be farther away from the correct one and a divergent pattern of iterations set up. This will rapidly lead to an unstable condition in which the computer ceases to produce meaningful results. It would be wise when working with a new system to build into the program protection against this occurring, in the form of a stop signal or other such means. On the other hand if the correction be insufficient, then more iterations than are absolutely necessary will be required and valuable computing time used.

Experiments were conducted with various values of  $G_s$  for the system used in this work and eventually the value of 0.01745 was decided upon. It was found that a value of 0.2 radian or over led to a diverging solution. The suitability of the factor was determined on the basis of the number of iterations necessary to arrive at the solution. With  $G_s$  of 0.01745 it was found that five iterations were sufficient for the system. As a matter of interest the time taken for the five iterations was about fifteen seconds. It was generally found that for  $G_s$  of around this magnitude between five and ten iterations were sufficient to arrive at a solution. It was also noted that once  $G_s$  became less than 0.005 the number of iterations started to increase rapidly. It was also found that once  $G_s$  was found for a system that value remained suitable for all calculations on the system. If necessary in the initial program for the system solution a number of different values for  $G_s$  can be inserted, one solution obtained and by inspecting this the most suitable value determined.

Having adjusted the appropriate phase angle the machine now will return to the start of the loop and recalculate the system using the new phase angles. Eventually it will have chosen such values of phase angles that the  $Z_i$  will either all be zero or very close to it. In general if  $Z_1$  is very close to zero then so also will the other two be. In a large system this condition will not be sufficient and an additional condition say half of all the  $Z_i$  be close to zero inserted.

In any modern computer the time taken for the calculation is normally less than the time taken for the input output devices to print the results. Accordingly while the machine can print out every piece of data, valuable time is wasted in doing this. Accordingly only essential data should be

printed. In this thesis the various steps were printed out in order to be able to follow each calculation but in a normal problem only the results of the final iteration should be printed.

The second stage of the solution is that shown in flow chart No. 2 in figure 7. This solution starts with the phase angles determined in the previous stage and these are used initially in each calculation. The voltage magnitudes are now the variables with one exception - one voltage in the system must be fixed. This is not a very great restriction as in any practical system there will be at least one voltage whose magnitude cannot be changed. In practice it will be found that there will be considerably more than one voltage subject to this condition. It is also evident that the more voltages which are fixed in magnitude the easier will be the job for the computer.

The machine now considers each voltage to vary between 80% and 120% of the values used in Stage 1. The choice of these numbers is arbitrary and these figures were used to ensure covering the minimum power input point. With experience these values could be changed to more suitable values from the point of view of computing time. The fixed voltages, of course, do not vary.

The above will give rise to a number of voltage profiles and for each profile the power input to the system will be optimized. For every voltage profile the computer will print out the profile and the power input to the system. There are two ways of concluding the calculation depending on which is required - a series of profiles and power inputs or the absolute minimum only. In the right hand loop there is a box labeled "Is  $P_t$  less this time than last?" If all profiles are required then this box is not

necessary and a straight through line is sufficient. If the absolute minimum is required this box will enable the machine to determine when it has reached the absolute minimum and it will stop there and not calculate further. Since it approaches the minimum gradually and then departs from it, a simple comparison test will tell when the minimum has been reached.

It should be pointed out that the number of variations possible in this type of calculation is endless and that those listed are only one of many. They were chosen because they were deemed suitable for this work but should by no means be considered the only ones possible. The correct choice of computer program, as always, depends on how much information is needed. This work only purports to give the general method of finding the minimum input to the system. Refinements follow depending on the particular system under consideration.

For example the various boundary conditions for the system could be inserted into the computer program. It might be such that limits are necessary on the watt and var outputs of the various generators. Another condition might be a limit on the voltage either at a generator or at some point in the system. This is particularly important in view of the fact that in the program listed in this work the computer is given complete freedom in the choice of voltage. Often the considerations of a customer will dictate the maximum and minimum voltages tolerable at his plant.

Alternatively there may be capacitors in the system which switch on automatically at fixed times during the day. If this should be the case, then on scheduling the generation during a given day different voltage limits will apply at different hours during the day.

## C. Solution for Three Machines

The results of Example 1 are given in Table I. For this example  $E_1$ ,  $E_2$ ,  $E_3$  were all assumed to be 1.0 per unit and the local loads all equal to 0.5 at each generator. This example was worked to an extreme in accuracy in order to illustrate the approach of the computer to the solution. Four iterations would normally be sufficient to give reasonable accuracy as thereafter the gain is only 0.0001% or an insignificant amount. For this example it was assumed that the phase angles were almost known, and values of 0.08727, 0.6109 and 0 radians respectively were assumed for the angles of the voltages at each of the three generators. These values were selected arbitrarily and were based on previous calculations made on the system.

In order to illustrate that the values of phase angles used to start the iteration can be any values whatsoever, Example 2 was worked. This is the identical same example as Example 1 except that the initial values of the phase angles are assumed to be 1 radian each. The results are in Table II and can be seen to be identical with Example 1. A further example was also worked setting the phase angles all equal zero and the same result obtained.

Example 3 results are tabulated in Table III. In this example the local loads were changed to 1.0 at each generator and the initial values of the phase angles chosen as 0.5235, 0.48860 and 0.40135 radians respectively. The reason these values were selected was to demonstrate that the initial values are of no importance. Any three values will do.

It is interesting to note when comparing Examples 1 and 3 that the share of the total load assigned to each generator is not the same. This

is illustrated in figure 11. It is evident from this that as the total system load increases, generator 3 takes more of the load and generator 1 less. This is not only due to the difference in the incremental rate curves but also due to the penalty of transmission losses which arise in the supplying of power from generator 1 to generators 2 and 3. The curves in figure 11 are really drawn for only two points and straight line relationship assumed in between. In a practical system many points would be taken and more accurate curves drawn. However these do demonstrate the effect of different incremental rates.

If there were no transmission losses in the system then one would expect all the generators to operate at equal incremental rates. However, when the losses are taken into account, the incremental rates do vary considerably from equality and this is very clearly illustrated in the examples.

The next stage of the solution is to solve the problem for the various voltage profiles. This was done in two different manners in order to broaden the results. First  $E_2$  and  $E_3$  were fixed at 1.0 per unit each and  $E_1$  allowed to vary from 0.80 to 1.15 and the power input to the system calculated with each profile being optimized by the choice of suitable phase angles as in stage 1. The results of this are tabulated in Table IV. The results of this are very interesting. They show that the minimum power input to the system occurs for  $E_1$  equal 1.05 per unit. Since the calculations were done in steps of 0.05, obviously smaller steps should be performed around this region but the results on this are clear enough to illustrate in what region the optimum lies. Even more interesting is the rate at which the power input starts to climb after the voltage reaches this level. It is also clear that the input at this voltage level is some-



what lower than that obtained in Example I.

At the same time in order to illustrate the savings involved, a study was run and the power input to the system calculated for equal incremental rates at the generators. This gave an input of 6.361026 to the system. In stage I the input had been reduced to 6.356304 and from Table IV it is noted that the absolute minimum input is 6.35480. The savings in the first case are 0.4722% and in the second case 0.6226% which is a considerable saving. The larger the system, the larger the dollar savings involved by using this method.

The above results can then be stated as "In a multiple machine system, if at least one voltage be fixed in magnitude, the minimum power input to the system will exist for a definite voltage profile of the remainder of the system and this profile will not be the highest possible voltages at each machine".

In order to test further the above principle, Example 5 was worked. This was the same system as before only this time  $E_3$  was fixed at 1.0 per unit.  $E_1$  was allowed to vary from 0.90 to 1.10 and  $E_2$  from 0.90 to 1.10 and the power input to the system calculated. The results are tabulated in Table V. From these results it can be seen that if  $E_1 = 1.05$ ,  $E_2 = 1.05$  and  $E_3 = 1.00$  then the power input to the system would drop still further to 6.34963927, a savings of 1.13333 per cent over the equal incremental rate or no transmission loss system. This is a considerable savings.

The results of Example 5 bear out the principle previously stated and show how to obtain the optimum profile of the system. The results listed in Table 5 do not purport to give the ultimate absolute minimum input to

Table I. Summary of results of Example 1

	Trial 1	Trial 2	Trial 3	Trial 4	Trial 5	Trial 6	Trial 7
$\delta_1$	.08727	.09053	.09053	.09053	.09053	.09053	.09053
$\delta_2$	.06109	.06109	.06109	.06152	.06130	.06141	.06136
$\delta_3$	.00000	.00000	.00139	.00139	.00139	.00139	.00139
$P_{g_1}$	.81239	.83359	.83021	.82846	.82934	.82889	.82912
$P_{g_2}$	.57883	.56595	.56172	.56472	.56320	.56397	.56358
$P_{g_3}$	.12843	.12137	.12831	.12709	.12770	.12739	.12755
$\xi_1$	1.21662	1.23692	1.23366	1.23199	1.23284	1.234241	1.23263
$\xi_2$	1.28950	1.27698	1.27288	1.27580	1.27432	1.27507	1.27369
$\xi_3$	1.37977	1.36783	1.37955	1.37749	1.37853	1.37801	1.37327
$Z_1$	-.18723	.04199	.01333	-.00673	.00342	-.00171	.00088
$Z_2$	.18284	.03045	-.02467	.01248	-.00632	.00320	-.00162
$Z_3$	.00439	-.07965	.01133	-.00575	.00289	-.00148	.00073
$P_t$	6.356579	6.356361	6.356306	6.356305	6.356304	6.356304	6.356304

$$E_1 = 1.0$$

$$P_{L_1} = 0.5$$

$$E_2 = 1.0$$

$$P_{L_2} = 0.5$$

$$E_3 = 1.0$$

$$P_{L_3} = 0.5$$

Table II. Summary of results of Example 2

	Trial 1	Trial 2	Trial 3	Trial 4	Trial 5	Trial 6	Trial 7	Trial 8	Trial 9
$\delta_1$	1.00000	1.00000	1.00000	1.00000	1.01053	1.01053	1.01053	1.01053	1.01053
$\delta_2$	1.00000	1.00000	.96007	.98041	.98041	.98041	.98180	.98111	.98145
$\delta_3$	1.00000	.91714	.91714	.91714	.91714	.92140	.92140	.92140	.92140
$P_{g_1}$	.50000	.69627	.85754	.77498	.84329	.83290	.82726	.83010	.82367
$P_{g_2}$	.50000	.75945	.46974	.61154	.56993	.55697	.56666	.56178	.56424
$P_{g_3}$	.50000	.76935	.18971	.13185	.10906	.13030	.12637	.12835	.12735
$\xi_1$	.93000	1.10734	1.26000	1.18105	1.28086	1.23624	1.23084	1.23356	1.23219
$\xi_2$	1.21333	1.45778	1.18435	1.32141	1.27603	1.26828	1.27768	1.27295	1.27533
$\xi_3$	1.99334	1.29234	1.48061	1.38415	1.34607	1.38156	1.37500	1.37830	1.37663
$Z_1$	-.03587	-.01522	.33887	-.60383	.15622	.04719	-.01769	.01496	-.00148
$Z_2$	-.01161	.22883	-.01166	.58103	.08795	-.07956	.04001	-.02014	.01011
$Z_3$	.47480	-.76654	.82719	-.0228	-.24417	.03237	-.02232	.005197	-.00865
$P_t$	6.550003	6.962721	6.365148	6.359150	6.356785	6.356337	6.356306	6.356305	6.356304

$$E_1 = 1.0$$

$$P_{L_1} = 0.5$$

$$E_2 = 1.0$$

$$P_{L_2} = 0.5$$

$$E_3 = 1.0$$

$$P_{L_3} = 0.5$$

Table III. Summary of results of Example 3

	Trial 1	Trial 2	Trial 3	Trial 4	Trial 5	Trial 6	Trial 7	Trial 8	Trial 9
$\delta_1$	.52350	.50991	.50991	.50991	.50991	.50991	.50991	.50991	.50991
$\delta_2$	.48860	.48860	.47641	.48487	.47901	.48307	.48027	.48221	.48086
$\delta_3$	.40135	.40135	.40135	.40135	.40135	.40135	.40135	.40135	.40135
$P_{g_1}$	1.43444	1.34478	1.39419	1.35886	1.38360	1.36713	1.37853	1.37062	1.37610
$P_{g_2}$	1.12465	1.17821	1.09266	1.15199	1.10992	1.13939	1.11967	1.13333	1.12387
$P_{g_3}$	.48069	.50944	.54343	.51981	.53614	.52481	.53265	.52721	.53098
$\xi_1$	1.85599	1.75904	1.81283	1.77540	1.80125	1.78330	1.79572	1.78711	1.79307
$\xi_2$	1.84420	1.90121	1.81039	1.87325	1.82967	1.85985	1.83893	1.85342	1.84338
$\xi_3$	1.96167	2.00882	2.06450	2.02581	2.05256	2.03400	2.04684	2.03795	2.04411
$Z_1$	.77881	-.35763	.32132	-.14953	.17644	-.04950	.10698	-.00146	.00736
$Z_2$	-.06420	.69856	-.48490	.33548	-.23267	-.16107	-.11164	.07732	-.00535
$Z_3$	-.71459	-.34093	.16358	-.18595	.56203	-.11157	.00466	-.07586	-.00200
$P_t$	8.747536	8.744691	8.743399	8.742763	8.742463	8.742318	8.742248	8.742217	8.742216

$$E_1 = 1.0$$

$$E_2 = 1.0$$

$$E_3 = 1.0$$

$$P_{L_1} = 1.0$$

$$P_{L_2} = 1.0$$

$$P_{L_3} = 1.0$$

the system but merely the minimum for the conditions stated. It is possible that there are yet other voltage profiles not considered that would lower the input even still further.

It is interesting to note that the Cyclone Digital Computer used in this thesis calculated any one of the results in Table V in from three to ten seconds. Using an IBM 7074 this should take of the order of two seconds. By hand the same calculations would take one person over three weeks working forty hours a week. It is possible therefore to use a digital computer to program hourly generator load schedules without much trouble. These can reflect the latest changes in the system and be right up to date. It is also possible to program the computer to operate an automatic load dispatcher. A 1.13333% savings in power is considerable and shows how a computer can more than pay for itself.

Table IV. Summary of results of Example 4

$E_1$	$E_2$	$E_3$	$P_{g1}$	$P_{g2}$	$P_{g3}$	$P_t$
0.80	1.00	1.00	.79977	.69780	.23793	6.6625375
0.85	1.00	1.00	.79830	.65082	.20102	6.5393117
0.90	1.00	1.00	.80208	.61276	.17062	6.4480135
0.95	1.00	1.00	.81205	.58364	.14632	6.3872817
1.00	1.00	1.00	.82912	.56358	.12755	6.3563041
1.05	1.00	1.00	.85299	.55184	.11564	6.3548006
1.10	1.00	1.00	.885271	.54968	.10826	6.3831210
1.15	1.00	1.00	.93086	.55402	.10373	6.4422104

$$P_{L_1} = 0.5$$

$$P_{L_2} = 0.5$$

$$P_{L_3} = 0.5$$

Table V. Summary of results of Example 5

$E_1$	$E_2$	$E_3$	$P_{t_{\min}}$
0.90	0.90	1.00	6.4636577
0.90	0.95	1.00	6.4399367
0.90	1.00	1.00	6.4480135
0.90	1.05	1.00	6.4884166
0.90	1.10	1.00	6.5623669
0.95	0.90	1.00	6.4312622
0.95	0.95	1.00	6.3936702
0.95	1.00	1.00	6.3872820
0.95	1.05	1.00	6.4123138
0.95	1.10	1.00	6.4696512
1.00	0.90	1.00	6.4290673
1.00	0.95	1.00	6.3772012
1.00	1.00	1.00	6.3563041
1.00	1.05	1.00	6.3662607
1.00	1.10	1.00	6.4076485
1.05	0.90	1.00	6.4574269
1.05	0.95	1.00	6.3905767
1.05	1.00	1.00	6.3548006
1.05	1.05	1.00	6.3496927
1.05	1.10	1.00	6.3754811
1.10	0.90	1.00	6.517351
1.10	0.95	1.00	6.434456
1.10	1.00	1.00	6.3831209
1.10	1.05	1.00	6.3626194

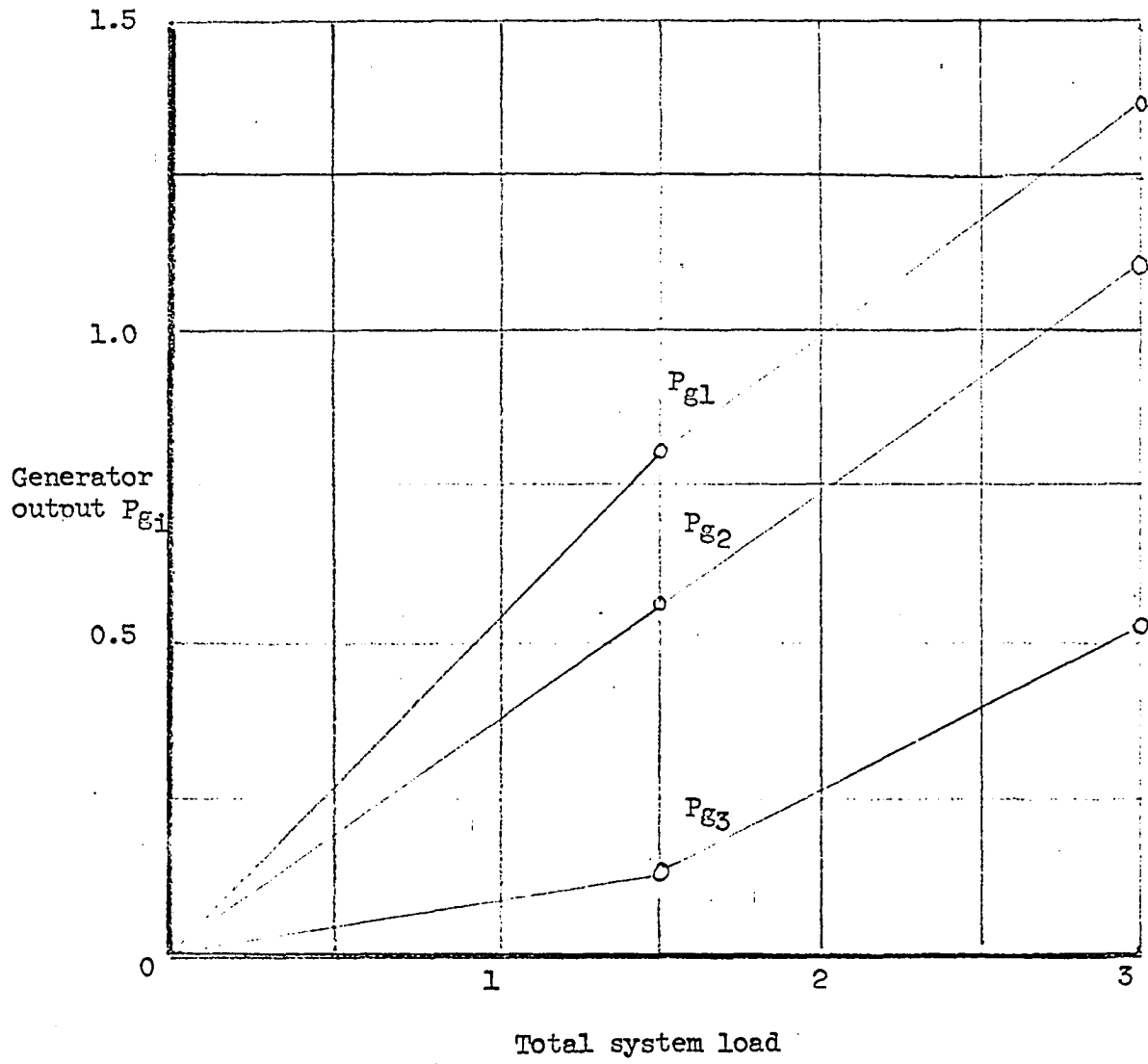

Figure 11. Generator schedule as a function of total system load.



## VI. DISCUSSION

This thesis gives a method for determining the minimum fuel input to a system of electrical plants all of varying fuel economics. It does this in two stages. The first presumes the voltage magnitudes in the system to be fixed by customer requirements and the voltage phase angles to be the independent variables. It then determines the correct phase angles for minimum fuel input to the system. Having done this it then proceeds in the second stage to determine the optimum voltage profile for minimum fuel input. This voltage profile may or may not be practical for the system. While calculating the optimum profile it also shows how to calculate a number of profiles at or near the optimum some of which will be physically realizable. The actual one to be used may be determined by the operator. Alternatively the physical limits of the system can be programmed into the computer which, if hooked up with an automatic load dispatching unit, will then schedule the generation automatically.

It is assumed for the purpose of the thesis that each generating plant is in economic balance with every other and that all plants are considered simultaneously. If two plants are electrically remote from each other then there will be little economic relation between the two owing to the high transfer impedance. If, on the other hand, the transfer impedance is negligible or very small then they will tend to operate at the same incremental rate and behave as one plant.

The digital computer is ideally suited to this method and this problem as it can calculate in a matter of seconds what takes weeks by long-hand methods. It can be easily programmed for hourly generation schedules.

The principle upon which the thesis is based states that for a

multiple machine system if at least one voltage be fixed, then there will be one voltage profile which will give minimum fuel input to the system and that in general this will not be the highest values of the remaining voltages.

George, Brownlee and Lagerstrom have done most of the work in this field and it is interesting to compare their work and methods with the results of this thesis. George based his work on calculating the losses in the lines and expressing them in terms of real power flow at the terminals. This method is fine for calculating the losses but it must be remembered that the losses in themselves are not that important. The only criterion for optimum system operation is that the cost of fuel input be a minimum. It is a mistake to consider each line separately or together with other lines and then to try and minimize the losses. Many of the previous workers in this field have tended to go in this direction. While the losses in themselves may be very interesting, how they occur, where they occur or of what magnitude they be is of absolutely no importance in optimizing the system. Only by considering the total input to a system as a whole can a true cost minimum be obtained. While this thesis does not take the losses into account directly, they do exist as during the calculations both  $P_{in}$  and  $P_{ni}$  are calculated and the difference between these two quantities will give the losses. Var flow is also taken into account albeit indirectly but there are no limits placed upon the var flow. It might be worthwhile investigating further into what limits should and could be placed upon var flow. It is very possible that the absolute optimum power input as given by this thesis might give a physically unrealizable system. To avoid this a number of profiles around the optimum are given, one of

which can be realized. There is considerable area here for further work.

Starting with the input data a major problem for previous workers was in that the methods available for calculating transfer impedances were not very accurate to say the least. The most common method was the network analyzer. However with the new methods described in the literature, it is possible to calculate these to any degree of accuracy desired. This removes one major area of controversy.

The representation of the voltage of the system is also a subject of discussion. The ideal voltage and the desired are not always the same. This thesis does not take into account what is ideal from a system point of view and therefore in general some human coordination may be necessary. The choice of the voltage profile in Examples 1 and 2 is based on system experience. As seen in Examples 4 and 5 this profile differs quite considerably from the optimum from a cost point of view. It is probable in any solution to the problem that a compromise will have to be reached. Such compromise in general is beyond the reach of a computer and needs human aid.

As mentioned earlier the choice of initial phase angles is immaterial, though the closer the choice is to the final solution the more rapidly will the computer perform the iteration.

The representation of the input-output curves of each plant by a power series is also open to question. Other methods have been the multiple straight line method. The power series method is certainly more accurate than this but there is no reason why the computer cannot be programmed to store the whole curve. By doing this any inaccuracy in this section would be eliminated. It would also give a much more accurate incremental

rate curve. The reason such a method was not used in this thesis was that for the three machine system chosen the power series equations were already known and it was felt there would be little gain in accuracy. However in a multiple machine system there would be a worthwhile gain and the complete programming of the curve is therefore recommended.

The decision on how close  $Z_1$  should be to zero is also important. Obviously it will need an almost infinite number of iterations to reach zero but a practical limit is reached much before that. In Example 1 two iterations gives the answer to within 0.003%, three iterations bring it within 0.00003% and four iterations to within 0.000014%. After this the gain becomes minute. Assuming a figure of four iterations, it is found that  $Z_1$  is 0.0133,  $Z_2$  is -0.024 and  $Z_3$  is 0.011. It is suggested therefore that once  $Z_1$  reaches 0.0100 the iteration process be declared stopped. In the program used in this work the process was not stopped until  $Z_1$  became 0.001. In practice this accuracy would be entirely unnecessary. At this stage the question may well arise as to why bother whether four or six iterations are necessary when it only takes three to five seconds per iteration. The problem is that while each iteration may take only that time in a given system there may well be a million iterations in the overall solution and every iteration removed is time saved.

The choice of the convergence factor  $G_s$  is at present a trial and error approach. This convergence factor for this work was chosen as 0.01745 as this value seemed to give satisfactory results. However later on in the work it was noticed that this value tended to overcorrect somewhat and it is now believed that it could be reduced even further. Further investigation into this factor might well be rewarding as it is the key to the

whole solution and a trial and error method of arriving at a key is never satisfactory. The value chosen in this thesis however is believed to be satisfactory for most systems though there is no mathematical proof to back this statement. It would certainly appear that any factor greater than this value would overcorrect and any values chosen should be less than this figure. It is also interesting to note that 0.01745 radian is exactly one degree. It might also be pointed out that in any event it is very unlikely that convergence will be reached in less than four iterations at anytime. Other convergence factors were tried of greater value than 0.01745 and the divergence from the solution was readily apparent. It was most disconcerting to note that when the computer became confronted with this condition it lost its head, so to speak, and went on a rampage offering meaningless results. It is recommended that in a new system some means be built into the computer program to detect this condition as otherwise valuable computing time would be wasted. At no time using a value of 0.01745 was this condition detected. It is believed that there is a definite connection between the convergence factor and the voltage level of the system though again this cannot be proved and was only noted in examining the results. The greater the voltage spread in the system the smaller appeared to be the optimum convergence factor.

Turning to the results and comparing them with other methods in this field, Brownlee did some work for two machines. Lagerstrom has shown that the basic method used in this work does reduce to Brownlee's method for two machines only but that Brownlee's method does not extend to this for multiple machine systems. Brownlee's methods certainly do not apply to systems containing loops. He approached the problem through the idea of

incremental losses but neglected to express the total system input or to differentiate it to find the economic loading criteria. He furthermore has not worked any multiple machine examples and in the two and three machine examples he has worked he simplifies the mathematics considerably by making unreasonable assumptions. Utilizing these assumptions the conclusion is reached that the phase angle method is inferior, Kirchmayer in his comments on this notes that the extension of the method to more than three machines may be cumbersome so does not bother. Lagerstrom developed his for three machines and the results he obtained and those obtained by the author of this work are identical where the work coincides. Lagerstrom however did not attempt to optimize the voltage magnitudes as well and all of his work was done on a hand calculator.

An interesting problem also arises on the var flow within the network. Some further work should be done on the question of how the supplying of vars at various points in the network would affect the cost of the input. It might conceivably be cheaper to supply the vars by means of capacitors or other means than to follow the var flow profile which would follow from the voltage profile determined in this work. There is at present no references in the literature to work done on this particular problem.

The choice of the Cyclone Digital Computer for this thesis was dictated by economic reason. The IBM 7074 would be a more suitable computer and the new IBM System/360 announced on April 10, 1964 would be even more suited to the solution of the problem. The choice of a language would depend on the type computer and is not critical. The Fortran language and the IBM 7074 would make a very excellent combination. In a large system

the memory capacity of the machine would be important and if a large power company were to adopt this method then the system/360 would be more suited as it can be added to without trouble as the system grows larger.

It is very hard to foresee what problems would arise on the convergence of the solution in a very large system. Some further research should be undertaken in this direction also.

In conclusion it may be stated that the method offered in this thesis updates Brownlee's, Kirchmayer's and Lagerstrom's work and adapts it to the digital computer. When used in conjunction with Glimm and Kirchmayer's digital programs for determining transfer impedances a method is available for calculating the accurate optimum fuel input to a system. This method is not believed to suffer from any of the criticism directed at earlier methods in this field. There are no restrictions on the system other than that one voltage at least be fixed and this is not very restrictive as in general more than one voltage will be fixed by system considerations. Most methods to date have expressed an accuracy based on similarity of the  $R/X$  ratios of the various lines. No such restriction applies in this method and it gives results irrespective of these ratios. The method is still capable of further refinement and development and when this has been done it is believed that an accurate and easily computable method will have been obtained for determining the generation schedule of a multi-machine electrical system which will give the minimum fuel input cost.

## VII. SUMMARY

This thesis demonstrates the principle that "in a multi-machine electrical system having plants of varying fuel economies, if at least one of the voltages be fixed in magnitude, then there will be one voltage profile which will give minimum fuel input to the system and that this profile will not necessarily be the highest voltages possible at the remaining generators".

It demonstrates how to obtain this minimum fuel input in two steps. It first considers the voltage magnitudes to be fixed and the voltage phase angles to be variable. It finds the minimum fuel input under these conditions by an iterative solution. It then iterates around this voltage profile to find the absolute minimum system input. It demonstrates that there will be a savings of at least 1.1% by using this method rather than the method where transmission losses are neglected.

The method of solution is by digital computer and consists of the following steps:

1. For the entire system determine the transfer impedances among all possible pairs of generator terminals denoting any interconnection points as generator terminals. This may be done either by setting the system up on a network analyzer or by a computer program selected from those available for this purpose.

2. Determine the shunt load impedances to be applied to these terminals and also find the power which they will demand from the network.

3. Determine the fuel input-output characteristic of each plant. This will be programmed directly into the computer or can be set up as a



power series. Plant generated output will be the variable.

4. Determine the incremental rate curves for each plant by differentiating the input-output characteristic.

5. Assign initial values of voltage phase angles to the system. These may be chosen arbitrarily but for minimum iterations they should be chosen close to the expected solution. Fix the voltage profile of the system in magnitude.

6. Form the phase angle differences between all pairs of generators.

7. From equations 35 and 38 find the values  $P_i$  for each generator. Combine these with the local loads as in equation 39 to get the generator power outputs  $P_{g_i}$ .

8. Determine incremental rates for each plant by substitution of  $P_{g_i}$  into equations 80, 81 and 82.

9. Evaluate the combinations  $X_{ij}$  as defined by equation 76.

10. Combine the products  $X_{ij}$  as required by equations 65, 66 and 67 to get the partial derivatives of  $P_t$  with respect to the voltage phase angle  $\delta_j$ .

11. For the next iteration change  $\delta_j$  by adding or subtracting  $G_s \cdot Z_j$  to the value originally used at the start of the last iteration. Correct  $\delta_j$  by taking the largest  $Z_j$  and correcting in the opposite direction as indicated by the sign on this derivative. If the derivative is negative, increase the angle and vice versa.

12. Repeat the above steps until  $Z_i$  is either zero or sufficiently close to it to be neglected. Then print  $P_t$ . This is the minimum input for this voltage profile.

13. Chose many voltage profiles within the region of the initial one

chosen and by completing the above steps for each profile determine which profile gives minimum input. Print this profile and input and other profiles and inputs close to this value.

## VIII. REFERENCES

1. Brown, R. J. and Tinney, W. F. Digital solutions for large power networks. Am. Inst. Elect. Engr. Transactions 76: 347-355. 1957.
2. Brownlee, W. R. Coordination of incremental fuel costs and incremental transmission losses. Am. Inst. Elect. Engr. Transactions 73: 529-541. 1954.
3. Brudenhall, R. N., Gilbreath, J. H. and Dobson, W. A. Computer scheduling of generation. Amer. Power Conf. Proceedings 25: 879-887. 1963.
4. Cahn, C. R. The derivation of incremental and total loss formulas from functions of voltage phase angles. Am. Inst. Elect. Engr. Transactions 74: 161-176. 1955.
5. Cahn, C. R. Discussion of Reference 4. Am. Inst. Elect. Engr. Transactions 74: 516. 1955.
6. Calvert, J. F. and Sze, T. W. Some general theorems on power flow in linear networks. Am. Inst. Elect. Engr. Transactions 75: 984-988. 1956.
7. Calvert, J. F. and Sze, T. W. A new approach to loss minimization in electric power systems. Am. Inst. Elect. Engr. Transactions 77: 1439-1446. 1958.
8. Dunstan, L. A. Digital load flow studies. Am. Inst. Elect. Engr. Transactions 73: 825-832. 1954.
9. Early, E. D., Watson, R. D. and Smith, G. L. A general transmission loss equation. Am. Inst. Elect. Engr. Transactions 74: 510-520. 1955.
10. George, E. F. Intrasystem transmission losses. Am. Inst. Elect. Engr. Transactions 62: 153-158. 1943.
11. George, E. F. A new method of making transmission loss formulas directly from digital load flow studies. Am. Inst. Elect. Engr. Transactions 78: 1567-1573. 1959.
12. Glimm, A. F., Habermann, R. Jr., Henderson, J. M. and Kirchmayer L. K. Digital calculation of network impedances. Am. Inst. Elect. Engr. Transactions 74: 1285-1297. 1955.
13. Glimm, A. F., Habermann, R. Jr., Kirchmayer, L. K., and Thomas, R. W. Automatic digital computer applied to generation scheduling. Am. Inst. Elect. Engr. Transactions 73: 1267-1275. 1954.
14. Glimm, A. F., Kirchmayer, L. K. and Stagg, G. W. Analysis of losses in interconnected systems. Am. Inst. Elect. Engr. Transactions 71: 796-808. 1952.

15. Glimn, A. F. and Stagg, G. W. Automatic calculation of load flows. Am. Inst. Elect. Engr. Transactions 76: 347-355. 1957.
16. Hardner, E. L., Jacobs, W. E. and Harker, D. C. Loss evaluation. II. Current and power-form loss formulas. Am. Inst. Elect. Engr. Transactions 73: 716-731. 1954.
17. Kirchmayer, L. K. Economic operation of power systems. New York, John Wiley and Sons, Inc. 1958.
18. Kirchmayer, L. K. Economic control of interconnected systems. New York, John Wiley and Sons, Inc. 1959.
19. Kirchmayer, L. K. and Stagg, G. W. Analysis of total and incremental losses in transmission systems. Am. Inst. Elect. Engr. Transactions 70: 1197-1205. 1951.
20. Kirchmayer, L. K. and Stagg, G. W. Evaluation of methods of coordinating incremental fuel costs and incremental transmission losses. Am. Inst. Elect. Engr. Transactions 71: 513-521. 1952.
21. Kron, Gabriel. Tensorial analysis of integrated transmission systems. I. The six basic reference frames. Am. Inst. Elect. Engr. Transactions 70: 1239-1248. 1951.
22. Lagerstrom, J. E. Economic power system loading. Unpublished Ph.D. thesis. Ames, Iowa, Library, Iowa State University of Science and Technology. 1958.
23. St. Clair, H. P. and Stagg, G. W. Digital computer solution of power system problems. Amer. Power Conf. Proceedings 20: 614-629. 1958.
24. Sherman, P. M. Programming and coding digital computers. New York, John Wiley and Sons, Inc. 1963.
25. Smith, R. E. and Johnson, D. E. Fortran autotester. New York, John Wiley and Sons, Inc. 1962.
26. Stevenson, W. D. Power system analysis. New York, McGraw-Hill Book Co., Inc. 1955.
27. Ward, J. B., Eaton, J. R. and Hale, H. W. Total and incremental losses in power transmission networks. Am. Inst. Elect. Engr. Transactions 60: 626-632. 1950.
28. Ward, J. B. and Hale, H. W. Digital computer solution of power system problems. Am. Inst. Elect. Engr. Transactions 75: 398-404. 1956.

## IX. ACKNOWLEDGEMENTS

The author wishes to thank his Major Professor, Dr. J. E. Lagerstrom without whose help this thesis would not have been possible. His continued assistance and advice and encouragement are appreciated. Thanks is also due Dr. W. B. Boast for his advice. Several members of the Department of Electrical Engineering staff contributed valuable advice and technical assistance.

## X. APPENDIX

```

*I1288  fort    michael grimes
c      evaluation for fixed magnitude voltage variable angle
1      array aa[4],bb[3],cc[3],dd[3,3],ee[3,3],ff[3],gg[3,3],mm
      [3,3],hh[3,3]
2      do 3 i = 1,4
3      read aa[i]
4      do 5 i = 1,3
5      read cc[i]
6      array x[3,3], y[3,3], z[3], t[4], r[3,3], s[3,3]
8      do 10 i = 1,3
9      do 10 j = 1,3
10     read dd[i,j]
11     do 13 i = 1,3
12     do 13 j = 1,3
13     read ee [i,j]
14     do 15 i = 1,3
15     read ff[i]
16     do 18 i = 1,3
17     do 18 j = 1,3
18     gg[i,j]=ff[i]-ff[j]
19     go to 121
21     y[1,1] = 0.12*bb[1]*bb[1]+0.76*bb[1]+0.520
22     y[2,2] = 0.08*bb[2]*bb[2]+0.88*bb[2]+0.75333
23     y[3,3] = -0.04*bb[3]*bb[3]+1.68003*bb[3]+1.16333
24     do 25 i=1,3
25     punch y[i,i],/
31     do 37 i = 1,3
32     do 37 j= 1,3
33     if (i-j) 35,37,35
35     s[i,j]=sin(ee[i,j]+gg[i,j])
37     continue
371    do 375 i=1,3
372    do 375 j=1,3
373    if (i-j) 374,375,374
374    r[i,j]=aa[i]*aa[j]*y[i,i]/dd[i,j]
375    continue
376    do 379 i=1,3
377    do 379 j=1,3
378    x[i,j]=r[i,j]*s[i,j]
379    continue
51    z[1]=x[1,2]+x[1,3]-x[2,1]-x[3,1]
53    z[2]=-x[1,2]+x[2,1]+x[2,3]-x[3,2]
55    z[3]=-x[1,3]+x[3,1]-x[2,3]+x[3,2]
56    punch z[1], z[2], z[3],/
57    if (mag(z[1])-.001) 114,114,71
71    if (z[1]) 72,114,73
72    if (z[2]) 101,114,74
73    if (z[2]) 75,114,111

```

```

74     if (z[3])          105,114,103
75     if (z[3])          107,114,109
101    ff[3] = ff[3]-mag(z[3])*0.01745
102    go to 112
103    ff[1] = ff[1]+mag(z[1])*0.01745
104    go to 112
105    ff[2] = ff[2]-mag(z[2])*0.01745
106    go to 112
107    ff[1] = ff[1]-mag(z[1])*0.01745
108    go to 112
109    ff[2] = ff[2]+mag(z[2])*0.01745
110    go to 112
111    ff[3] = ff[3]+mag(z[3])*0.01745
112    punch ff[1], ff[2], ff[3],/
113    go to 16
114    continue
116    punch aa[4],/
117    go to 141
121    do 126 i = 1,3
122    do 126 j = 1,3
123    if (i-j)          124,126,124
124    mm[i,j]=(-aa[i]*aa[j]*cos(ee[i,j]+gg[i,j])/ad[i,j])+
        (aa[i]*aa[i]*cos(ee[i,j])/ad[i,j])
126    continue
127    bb[1] = mm[1,2]+mm[1,3]+cc[1]
128    bb[2] = mm[2,1]+mm[2,3]+cc[2]
129    bb[3] = mm[3,1]+mm[3,2]+cc[3]
130    punch bb[1], bb[2], bb[3],/
131    t[1]=2.28+.52*bb[1]+.38*bb[1]*bb[1]+.04*bb[1]*bb[1]*bb[1]
132    t[2]=1.59+.75333*bb[2]+.44*bb[2]*bb[2]+.02667*bb[2]*bb[2]
        *bb[2]
133    t[3]=1.04+1.16333*bb[3]+.84002*bb[3]*bb[3]-0.01333*bb[3]
        *bb[3]*bb[3]
134    t[4]=t[1]+t[2]+t[3]
135    punch t[4],/
136    go to 21
141    punch t[4]
142    stop
143    end

```

```

c      program for evaluation minimum power input by iterating
c      all voltage profiles twenty per cent either side voltage
c      profile used above holding phase angles variable starting
c      phase angles found end above solution

```

```

*I1288  fort      michael grimes
1      array aa[4],bb[3],cc[3],dd[3,3],ee[3,3],ff[3],gg[3,3],mm
        [3,3],h[5]

```

```

2 do 3 i = 1,4
3 read aa[i]
4 do 5 i = 1,3
5 read cc[i]
6 array x[3,3], y[3,3], z[3], t[4], r[3,3], s[3,3], k[5]
8 do 10 i = 1,3
9 do 10 j = 1,3
10 read dd[i,j]
11 do 13 i = 1,3
12 do 13 j = 1,3
13 read ee [i,j]
14 do 15 i = 1,3
15 read ff[i]
151 do 152 i=1,5
152 read h[i]
153 do 154 i=1,5
154 read k[i]
155 do 1411 m=1,5
156 do 1411 n=1,5
157 aa[1]=h[m]
158 aa[2]=k[n]
16 do 18 i = 1,3
17 do 18 j = 1,3
18 gg[i,j] = ff[i]-ff[j]
19 go to 121
21 y[1,1] = 0.12*bb[1]*bb[1]+0.76*bb[1]+0.520
22 y[2,2] = 0.08*bb[2]*bb[2]+0.88*bb[2]+0.75333
23 y[3,3] = -0.04*bb[3]*bb[3]+1.68003*bb[3]+1.16333
24 do 25 i=1,3
25 punch y[i,i],/
31 do 37 i = 1,3
32 do 37 j = 1,3
33 if (i-j) 35,37,35
35 s[i,j]=sin(ee[i,j]+gg[i,j])
37 continue
371 do 375 i=1,3
372 do 375 j=1,3
373 if (i-j) 374,375,374
374 r[i,j]=aa[i]*aa[j]*y[i,i]/dd[i,j]
375 continue
376 do 379 i=1,3
377 do 379 j=1,3
378 x[i,j]=r[i,j]*s[i,j]
379 continue
51 z[1]=x[1,2]+x[1,3]-x[2,1]-x[3,1]
53 z[2]=-x[1,2]+x[2,1]+x[2,3]-x[3,2]
55 z[3]=-x[1,3]+x[3,1]-x[2,3]+x[3,2]
56 punch z[1], z[2], z[3],/
57 if (mag(z[1])-0.001) 114,114,71

```



```

71  (z[1])
72  (z[2])
73  (z[2])
74  (z[2])
75  (z[3])
101 ff[3] = ff[3]-mag(z[3])*0.01745
102 go to 112
103 ff[1] = ff[1]+mag(z[1])*0.01745
104 go to 112
105 ff[2] = ff[2]-mag(z[2])*0.01745
106 go to 112
107 ff[1] = ff[1]-mag(z[1])*0.01745
108 go to 112
109 ff[2] = ff[2]+mag(z[2])*0.01745
110 go to 112
111 ff[3] = ff[3]+mag(z[3])*0.01745
112 punch ff[1], ff[2], ff[3],/
113 go to 16
114 continue
116 punch aa[4],/
117 go to 141
121 do 126 i = 1,3
122 do 126 j = 1,3
123 if (i-j) 124,126,124
124 mm[i,j] = (-aa[i]*aa[j]*cos(ee[i,j]+gg[i,j])/dd[i,j]
) + (aa[i]*aa[j]*cos(ee[i,j])/dd[i,j])
126 continue
127 bb[1] = mm[1,2]+mm[1,3]+cc[1]
128 bb[2] = mm[2,1]+mm[2,3]+cc[2]
129 bb[3] = mm[3,1]+mm[3,2]+cc[3]
130 punch bb[1], bb[2], bb[3],/
131 t[1] = 2.28+.52*bb[1]+.38*bb[1]*bb[1]+.04*bb[1]*bb[1]
*bb[1]
132 t[2] = 1.59+.75333*bb[2]+.44*bb[2]*bb[2]+.02667*bb[2]
*bb[2]*bb[2]
133 t[3] = 1.04+1.16333*bb[3]+.84002*bb[3]*bb[3]-0.01333*
bb[3]*bb[3]*bb[3]
134 t[4] = t[1]+t[2]+t[3]
135 punch t[4],/
136 go to 21
141 punch t[4]
1411 continue
142 stop
143 end

```